

INSIDE!

Science-backed reasons why crochet is good for you

Make a moggy!



PURR MAGIC!

ISSUE ONE HUNDRED & SEVENTY

Simply Crochet

PATTERNS ♥ IDEAS ♥ YARN ♥ INSPIRATION ♥ TECH

PATTERNS IN SIZES UP TO 4XL



THE NEON EDIT



Ribbons & Roses kid's cardigan

SWEATER SEASON

Wrap up in handmade warmth

WINTER ACCESSORIES

COSY LAYERS



■ CUSHION SET ■ COLOURFUL RUG ■ BOOK COVER & MORE

WEST YORKSHIRE SPINNERS



Rawina

**Crochet Swirl Jumper by Cassie Ward
in Retreat Twist Chunky**

Discover your local stockist at wyspinners.com



01535 664500



Simply Crochet



New year, new you – and new clothes! Nothing beats taking an old garment and completely transforming it, or stitching accessories from scratch. Ready to make 2026 your most creative year to date? Turn the page for ideas!



Simply Crochet

ISSUE ONE HUNDRED & SEVENTY
CONTENTS



49

POLO NECK
JUMPER

Cover
STAR!

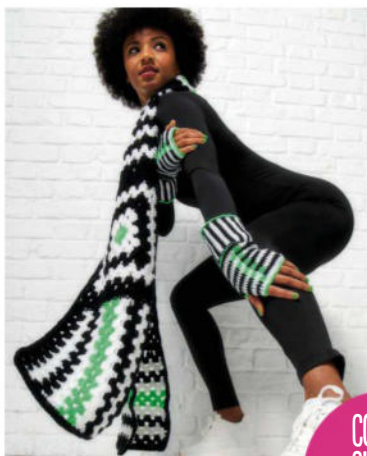

COLOUR
CHROME
COLLECTION
P14

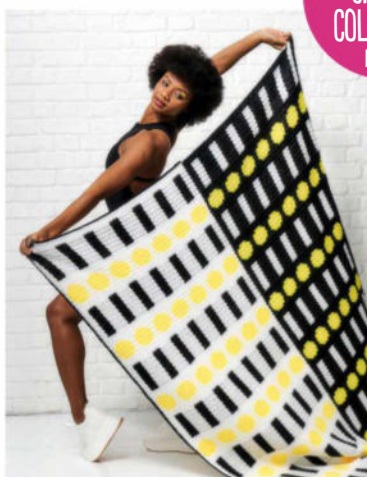

EXCITING CROCHET IDEAS TO INSPIRE YOU

14 COLOUR CHROME COLLECTION
27 NEON CROP TOP
31 AMIGURUMI CAT
37 EMBELLISH A HOOD
40 LELUJA BLANKET
42 SPRING BOOK COSY
44 TUNISIAN SCARF

49 POLO NECK JUMPER
52 FIRESIDE RUG
55 BEADED BRACELETS
56 BABY CARDIGAN
65 PAIR OF CUSHIONS

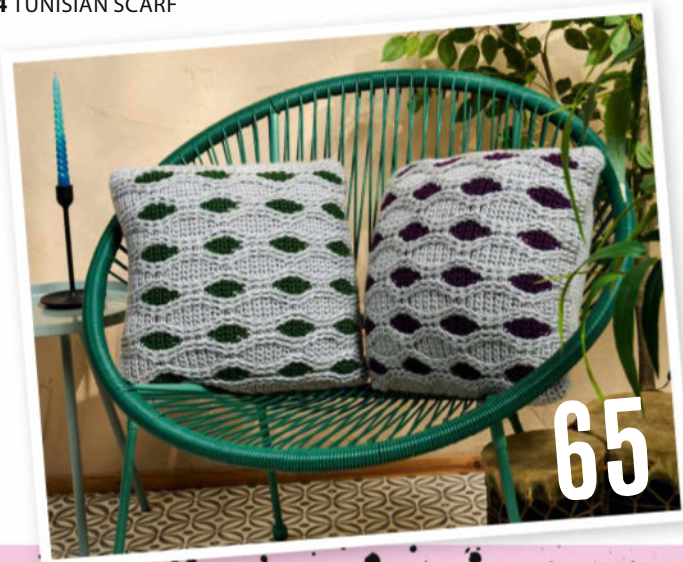

65



37



42

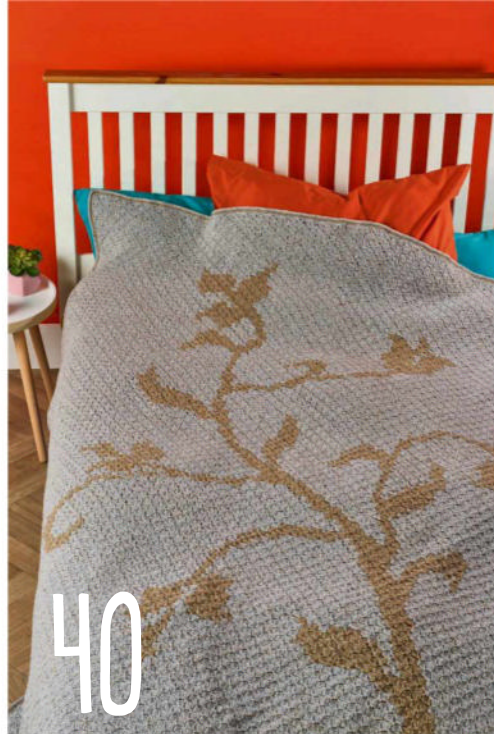

40



56



52



44
TUNISIAN
SCARF

GOOD READS

- 09** HOOKED
- 46** PROFILE: AMBER MILLARD
- 60** FEATURE: MATTERS OF THE MIND
It's official: crafting is good for you
- 63** BONUS: DIGITAL DOWNLOAD
- 70** SHOW US YOURS!
- 82** FAVE FOLLOW
What's new on social

HOW TO...

- 34** SUBSCRIBE
Never miss an issue!
- 67** YARN REVIEWS
Take a peek through our file windows
- 72** CROCHET UNRAVELLED
Save your scraps for new projects
- 75** THE GUIDE
Essential step-by-steps for you



55



27

31

*Merlin the
manvellous
moggy!*



To new starts...

What are your plans for 2026? While I did resolve to rescue my WIPs from their pile of shame, I'm also going to make the polo neck jumper on page 49 – I just can't resist! If your goal is to use up leftover yarn, check out our stash-busting rug on page 52, or turn to page 55 to make a stylish bracelet from your odds and ends. Plus, our guide on magic knots (page 72) will show you how to join your scraps into one ball! And for all you bookworms, turn to page 42 – you'll love our cosy book sleeve. Don't forget to share your makes with the hashtag #scrtreblemaker on Instagram, or join our Facebook group, Simply Crochet SCtreblemakers.



Sara

CONTRIBUTORS

Some of the names behind this month's patterns...



GEMMA WILLIAMS

Gemma designs nature-inspired, textured crochet patterns and works as a tech editor, helping makers and designers feel confident with every stitch. Find her rug on page 52.



CLAIRE FEARNLEY

Claire is a designer and avid yarn collector. She loves to experiment with construction techniques and stitches to create bold, vibrant accessories, like the bracelets on page 55.



PAULINE MORGAN

Pauline started crocheting 12 years ago and has since been completely hooked! She now loves designing colourful amigurumi and accessories. See her poncho on page 25.



DEB WARD

Deb trained in machine knitting but took up the hook around five years ago and has never looked back! She's a fan of all things retro and colourful, just like her wall hanging on page 22.

OTHER CONTRIBUTORS

Helen Anderson, Jess Bennett, Chloé Elizabeth Birch, Annelise Brant, Debora Bradley, Jude Curle, Tricia Fairburn, Jenny May Forsyth, Simone Francis, Jane Howarth, Maria Jęczmyk, Kelly Wilson Moore, Susan Pearson, Marianne Rawlins, Becky Skuse, Matt Spiers, Catherine Venner, Cassie Ward, Wool Couture

Simply Crochet

Editor Sara Huntington
Creative Lead Claire Watkins
Creative Designer Lois Brewer
Production Editor Tricia Fairburn
Technical Editor Paula Green
Cover Photography Steve Sayers
Photography Dave Gaudery, Steve Sayers

ADVERTISING

Commercial Brand Lead Rachael Hawkins
0117 300 8206
Brand Sales Executive Emily Hayes
0117 476 7315

MARKETING & SUBSCRIPTIONS

Senior Direct Marketing Executive Kate Jones
Head of Loyalty, CRM & Engagement Rosa Sherwood
Head of Acquisitions Clive Evans-Morris

CIRCULATION

Head of Newstrade Marketing Martin Hoskins
Newstrade Marketing Manager Janine Smith

PRODUCTION

Production Coordinator Lauren Morris
Production Manager Rose Griffiths
Group Production Manager Louisa Molter
Production Director Sarah Powell

BUYING TEAM

Karen Flannigan

LICENSING

Director of International Licensing & Syndication Tim Hudson

PUBLISHING

Director of Craft & Head of Content Liz Taylor
CEO Andy Marshall

SUBSCRIPTIONS

Call 03330 162 146* or subscribe online at
www.ourmediashop.com

NEED TO GET IN TOUCH?

EDITORIAL TEAM
simplycrochet@ourmedia.co.uk
SUBSCRIPTIONS TEAM
www.ourmediashop.com/contactus
03330 162 146*

NEXT ISSUE ON SALE
20 JANUARY 2026

No gift included? Ask your newsagent.
Covergift may be unavailable overseas.

*Calls from landlines will cost up to 9p per minute, depending on provider. Call charges from mobile phones will cost between 3p and 55p per minute, depending on provider, but are included in inclusive call packages. Lines are open 9am–5pm weekdays, and 8.30am–4.30pm on Saturdays.



Our Media Company is working to ensure that all of its paper comes from well-managed, FSC-certified forests and other controlled sources. This magazine is printed on Forest Stewardship Council® (FSC®) certified paper. This magazine can be recycled, for use in newspapers and packaging. Please remove any gifts, samples or wrapping and dispose of them at your local collection point.

The copyright in the patterns in this magazine are owned by or licensed to Our Media Ltd and are for readers' personal use only. Please do not share them online (even for free) or copy them multiple times without our permission. Where selling crafts based on these patterns is permitted (usually only to raise funds for charity), we'll say so on the page. All toys sold in the UK must meet the requirements set out in the Toy Safety Regulations 2011, with proof in the form of a CE Mark. You must take all necessary steps to comply with this important legislation. For more information, see gov.uk/ce-marking.

Our Media Limited (company number 05715415) is registered in England and Wales. The registered office of Our Media Limited is at Eagle House, Colston Avenue, Bristol, BS1 4ST. All information contained in this magazine is for information only and is, as far as we are aware, correct at the time of going to press. Our Media Limited cannot accept any responsibility for errors or inaccuracies in such information. Readers are advised to contact manufacturers and retailers directly with regard to the price of products/services referred to in this magazine. If you submit unsolicited material to us, you automatically grant Our Media Limited a licence to publish your submission in whole or in part in all editions of the magazine, including licensed editions worldwide and in any physical or digital format throughout the world. Any material you submit is sent at your risk. Although every care is taken, neither Our Media Limited nor its employees/agents or subcontractors shall be liable for loss or damage.

WWW.GATHERED.HOW/SIMPLYCROCHET

CASCADE YARNS®

FAMILY OWNED SINCE 1987

STONE HARBOR VEST

BY MELISSA LEAPMAN

FREE PATTERN S121

220 Superwash®

Sport Wave

100% WOOL



www.cascadeyarns.com

BERNAT[®]

Blanket
Patchwork[™]



OUR BESTSELLING CHENILLE YARN WITH A BRAND NEW DYE EFFECT THAT ADDS STRIPES OF VARYING LENGTH THROUGHOUT THE CAKE TO CREATE INTERESTING STRIPING PATTERNS FOR ALL PROJECTS

**NOW AVAILABLE FROM
WOOL WAREHOUSE | READICUT**

Hooked

IDEAS ♥ INSPIRATION ♥ ACCESSORIES ♥ WEBSITES ♥ EVENTS ♥ STUFF



Crafty new year

Losing track of all your WIPs? Scheepjes have launched a calendar for crafters, featuring 12 inspiring patterns for crochet, knitting and other yarn crafts. Inspired by a Dutch tradition, this calendar is not dated by year, so you can keep track of recurring events like birthdays and anniversaries by using the calendar again and again. The patterns are printed in Dutch with QR codes linking to the English versions. Hang it in your craft room or even the downstairs loo! Go to www.scheepjes.com/en to find a stockist.



GO WITH THE FLOW

If you're anything like us, you'll know the hypnotic pull of crochet. No sooner have you picked out your yarn than you're down the rabbit hole – and our spiral blanket is no exception! Designed by Kath Webber, this gorgeous cotton throw is made up of 81 swirly squares and worked in a combination of solid and variegated DK yarns. First published in *Simply Crochet* issue 46, the intermediate pattern could be yours for just £4. Head to www.gatheredshop.com to download the PDF. Now, listen carefully: you are feeling crafty. Very, very crafty...

New release

Cloud nine

Avalon (50g/82m) is a new chunky wool blend from Swiss brand LANGYARNS. Its core-spun construction provides strength but doesn't scrim on softness, and is hardy enough to be machine washed at 30°C. Available now from www.knitmcintosh.com



SWEET AS...

▼ Stylecraft have added four new shades to their mouthwatering Wondersoft Merry Go Round collection. Dew Drops, Fizzer, Sherbet Dip and Flying Saucer will have you reminiscing over childhood days at the sweet shop, with effortless colour changes that blend together like seaside rock. Find out more at www.stylecraft-yarns.co.uk where you can also browse a range of crochet patterns made with a combination of Wondersoft Merry Go Round and Stylecraft Special DK.



PUT THE KETTLE ON!

A mother-daughter duo in Ireland have gone viral on social media for their crochet content. Susan Banks from Dublin has been crocheting since she was a child. "She doesn't use patterns," says daughter Rachel. "She just looks at something and knows how to bring it to life." Initially selling hats and dolls' clothes at craft fairs, Susan was asked if she could make a Michael D Higgins (Irish politician) tea cosy. Susan committed, hooking up thousands of Michael 'Tea' Higgins cosies, alongside newly elected Irish president Catherine Connoll-tea. Follow Susan and Rachel on Instagram: @not_just_hats and TikTok: @notjusthats



WOOLLY GOOD

In true Yarnsmiths fashion, the Wool Warehouse team have conjured up 120 shades of their new Merino Aran range. Yes, 120! A follow-up to Merino DK and Merino Sock, Yarnsmiths Merino Aran is the ideal choice for thicker garments and blankets. If you're comfortable working with wool, Merino is an excellent choice, owing to its breathable and antibacterial nature. It's sourced from Australia and is certified as being non-mulesed. RRP £5 per 50g/75m, sale price £2.99. Available to buy now from www.woolwarehouse.co.uk

Editor's Choice

WHAT A CORKER!

This month Sara's resolved to finish her neglected WIPs – and it all starts with a lovely new project bag, obviously.

If there's one thing I can't get enough of, it's project bags. This is most likely because I have no end of projects on the go, but shush. The cork project bag from TOFT caught my eye, because – well, how could it not? Just look at it! It's stylish, it's sustainable, and it's easy to clean. What's not to love?

Designed by TOFT in Warwickshire and made in Portugal, this lovely pouch can hold up to 200g of yarn and includes a fixture for adding a wrist strap, so you can keep your crochet essentials close to hand. And just as no two stitches are the same, each bag has a

slightly different pattern, owing to its natural material. It's just one of the accessories in TOFT's bespoke cork range.

Is it waterproof? Oh, yes! Will it be ruined if you spill your tea/coffee/wine/energy drink? Unlikely – just grab a damp cloth and wipe clean. Cork makes a pliable fabric that keeps your precious makes safe and dry, and it can be harvested without causing any damage to the tree itself. Win-win.

The bag itself is lightweight and flexible, making it a great choice for crafting on the go – whether that's a short bus journey or a long haul flight. I'll be reaching for it when I pack for my 2026 holidays. Yes, I know it's early... but I am SO ready for mine!

Go to www.toftuk.com to buy, £29



Crochet community

Skills & events

10 JAN Crochet Beginners Day Workshop
£65, Logie Steading, Forres
www.logie.co.uk

17 JAN Make a Granny Square
£40, Yarny Bees, Lichfield, Staffordshire
www.yarnybees.co.uk

10 JAN Beginner Crochet Workshop
£92, Ginger Twist Studio, Edinburgh
www.gingertwiststudio.com

30 JAN Crochet Heart Bunting Workshop
£45, All About the Yarn, Somerset
www.allabouttheyarn.co.uk

INSPIRING BOOKS



TUNISIAN CROCHET TOPS

ASHLEY RIVAS
(£10.99, Page Street)
It's 2026 and your New Year's resolution is to learn Tunisian crochet – and

craft some trendy looks while you're at it. Naturally, you pick up Ashley Rivas' new book, knowing she'll guide you through every step of the process, helping you create wardrobe staples for all seasons. Available on Kindle now with the paperback version coming soon.



QUIRKY AMIGURUMI

ALLESHEN HAMILTON
(£21.99, Page Street)
If you've been following Alleshen on Instagram (@gheebeanscrafty)

you'll have heard about her new book. *Quirky Amigurumi* features 30 low-sew patterns for designing cute, silly and lovable creatures, ideal for both beginner and experienced hooksters. You can even stitch accessories for them to wear! Coming to UK bookstores on 12 January, early birds can preorder now.



PRIDE & PREJUDICE AMIGURUMI

SIOBHÁN EARDLEY
(£16.99, Dover Publications Inc)

Are you bookish as well as hookish? Do you know someone with a soft spot for classic literature? Siobhán Eardley's new book stars 12 Jane Austen characters to crochet, from the Bennet family and Mr Darcy to George Wickham. With full colour photos and step-by-step instructions, you'll soon have an entire clan of Regency-era characters. Available now.



MEGA YUMMY CROCHET

MIYA
(£19.99, World Book Media)

@miya_amigurumi is a Japanese author, crafter and crochet teacher whose latest book is truly mouthwatering! Hook up 26 larger than life treats, including hamburgers, hotdogs and macarons, and add a touch of whimsy to your living space. These oversized amigurumi toys can be used as cushions and pillows for kids, pets or the treat-loving adult in your life, and with stitch diagrams and written instructions, you'll be cooking up a storm! Available now.



HAPPY DAYS

You may already be familiar with Happy Place, a collaboration between Hobbii and Toni Lipsey. It's a lightweight blend of superwash Merino wool and breathable cotton, making it the ideal choice for multi-season makes. The wool fibres take the dye while the cotton does not, resulting in a melange effect. Hobbii are relaunching the entire palette with rich and moody shades inspired by winter woodland. Just the thing for starting a new project... or maybe even a CAL. Place your order at www.hobbii.co.uk



THE MOOD FOR FOOD

What's your New Year's resolution for 2026? If you're leaning towards exercise and veggies, Schiffer's peapod amigurumi kit could be the moral support you need. And if you're sticking with cakes and donuts then more power to you – there's a kit for that, too! Stitch a donut, cupcake or mug of hot cocoa and stay cosy this January. Retailing at £22.99 each, the kits are available from www.gazellebookservices.co.uk and contain all the materials you need to make these tasty treats, plus a video tutorial.

NORTHERN CHARM

▼ Dalesway Chunky is a new acrylic and wool blend from King Cole, available in 14 shades inspired by the Yorkshire countryside. Think clean lines, timeless charm and garments that are both stylish and practical. Each colour is named after a Yorkshire Dales location, including Appletreewick and Grassington. As such, whatever you make with this gorgeously soft yarn is stitched with the Spirit of the Dales. Tempted? We know we are. You can find a stockist at www.kingcole.com



SIX A SIDE

The classic hexi cardigan works up remarkably quickly, so if you're looking for a satisfyingly speedy new project, take a look at Gusto Wool's Square Up Jacket. The pattern is just £4 to download, with baby, toddler and adult sizes available. The fine yarn and three-quarter length sleeves make this a fab project to finish in time for spring. Yarn bundles are also available – go to www.gustowool.com to check out the colourways or buy the pattern as an instant PDF download.

Correction! In issue 169 we mistakenly credited the wrong designer for the Sleigh Bag. The correct designer is HAE Barker. We apologise for the mix-up.

Shop of the month

Alterknit Universe

Each issue we explore a UK yarn shop

Who's in charge? Karl Dixon has kept things going since partner Kim Smith passed away in May 2024.

Where can we find you? Cleeve, halfway between the beautiful Bristol and the iconic Weston-super-Mare.

What is your shop like? With our hand-painted murals, everything is bright and colourful. All our branding is hand-designed, and in some cases handwritten. Come by and see our six foot crocheted dragon!

Why should we visit? We vet all our suppliers to ensure they fall within one (ideally more) of our four ethos: ethical, local, natural or recycled. We ask our suppliers the hard questions so you can buy your yarn guilt-free.

Any events or workshops planned? We run crochet classes regularly, in small groups so you can have that personal touch. We also have a knit and crochet group that we run every Sunday, and offer beginner crochet granny square classes.

39 Main Road, Cleeve, Bristol, BS49 4NS
[@aushopuk](http://www.alterknituniverse.co.uk)



MOORLAND

CHUNKY

Enjoy creating with
our latest chunky yarn.

100%
Premium
Acrylic



Available in six beautiful
earthy tones with a muted,
tonal colour change.



Scan here for all
our latest patterns

Stylecraft
Member of the UK Hand Knitting Association

For all our latest patterns & yarns visit www.stylecraft-yarns.co.uk   For your nearest stockist telephone 01484 848435



FRESH PERSPECTIVE

Mint green is often thought of as a soft colour. Ramp up the saturation and pair it with black and white stripes and you'll think differently!



High voltage

A stark black and white backdrop gives these electric neons an extra boost, intensifying up the 'pop' factor!



LOOK HUES TALKING

Think you can't wear neon? Think again! Try small pops of electric pink next to a more understated black and white pairing. That's the secret to high voltage hues!



BLESSING AND A PURSE

This cute accessory may be small, but that splash of turquoise packs a good punch! The bag's construction means it can easily hold its shape – and your neon lippy.

COLOUR CHROME COLLECTION



BLANKET STATEMENT

Take a closer peek at the spots and stripes on this blanket. Anyone else see exclamation marks? It's a fitting symbol for the attention-grabbing colour combo in this collection, designed to turn heads.

RETRO FROM THE GET-GO

Crochet is your go-to craft for that chic '60s look, inspired by counterculture and saturated with bold style. True rebels will love these stripes and clashing colours.





GRANNY SQUARE SCARF

Claire Fearnley's statement scarf uses eye-catching geometric patterns and yarn held double for a bold look and cosy feel

■ Cygnet DK (100% acrylic, 100g/298m), 3 balls of Black (217), 2 balls of White (208), 1 ball of Bright Lime (6869)

■ A 6mm (US J/10) hook

TENSION

Tension is not critical, but it may affect the yarn quantities required

MEASUREMENTS

Scarf measures approx 240cmx35cm (94x14in)

NOTES

Scarf is made up of 7 Squares. Squares are sewn together into a strip to form the Scarf.

Scarf is crocheted with 2 strands of yarn held together, to create a chunky effect. You will need to wind the ball of Bright Lime into 2 balls before you begin.

There is a Diagram on page 81, which you can refer to when joining Squares.

GRANNY SQUARE SCARF

BASIC GRANNY SQUARE (MAKE 3)

Make 2 in first colourway and one in second colourway.

Using Bright Lime (Black), make a magic loop.

Round 1 (RS) Ch3 (counts as tr throughout), 2tr in loop, ch3, (3tr in loop, ch3) 3 times, ss to top of beg ch-3. [4 3-tr groups, 4 ch-3 sps]

Fasten off.

Join White (White) in any ch-3 sp.



Round 2 Ch6 (counts as tr, ch3 throughout), 3tr in same sp, ch1, (3tr, ch3, 3tr, ch1) in next 3 ch-3 sps, 2tr in last ch-s (same sp as beg ch-6), ss to third ch of beg ch-6.

[8 3-tr groups, 4 ch-3 sps, 4 ch-1 sps]

Round 3 Ss into ch-3 sp, (ch3, 2tr, ch3, 3tr) in same sp, ch1, 3tr in ch-1 sp, ch1, *(3tr, ch3, 3tr) in ch-3 sp, ch1, 3tr in ch-1 sp, ch1, rep from * twice more, ss to top of beg ch-3.

[12 3-tr groups, 4 ch-3 sps, 8 ch-1 sps]

Fasten off.

Join Black (Bright Lime) in any ch-3 sp.

Round 4 Ch6, 3tr in same sp, ch1, *(3tr, ch1) in each ch-1 sp across to corner, (3tr, ch3, 3tr) in ch-3 sp, ch1; rep from * around to end, 2tr in same sp as beg ch-6, ss to third ch of beg ch-6. [16 3-tr groups, 4 ch-3 sps, 12 ch-1 sps]

Round 5 Ss into ch-3 sp, (ch3, 2tr, ch3, 3tr) in ch-3 sp, ch1, *(3tr, ch1) in each ch-1 sp across to corner, (3tr, ch3, 3tr) in ch-3 sp, ch1; rep from * around to end, ss to top of beg ch-3.

[20 3-tr groups, 4 ch-3 sps, 16 ch-1 sps]

Fasten off.

Join White (White) in any ch-3 sp.

Rows 6-9 Rep Rounds 4-5, changing to Black (Black) at the end of Round 7.

[36 3-tr groups, 4 ch-3 sps, 32 ch-1 sps]

Round 10 Ch1 (does not count as st throughout), *dc in each st and ch-1 sp to corner, 3dc in ch-3 sp; rep from * around to end, ss to beg dc. [152 dc]

Fasten off and weave in ends.

STRIPED SQUARE (MAKE 2)

Using Black, ch40.

Row 1 (WS) 2tr in fourth ch from hook, (ch1, skip 3 chs, 3tr in next ch) 9 times, turn.

[10 3-tr groups, 9 ch-1 sps]

Row 2 (RS) Ch4 (counts as tr, ch1 throughout), (3tr in next ch-1 sp, ch1) 9 times, tr in final st, turn. [2 tr, 9 3-tr groups, 10 ch-1 sps]

Change to White.

Row 3 Ch3, 2tr in first ch-sp, (ch1, 3tr in next ch-1 sp) 9 times, turn. [10 3-tr groups, 9 ch-1 sps]

Rows 4-19 Rep Rows 2-3, changing colour as follows: Black at end of Row 4, White at end of Row 6, Bright Lime at end of Row 8, White at end of Row 11, Black at end of Row 13, White at end of Row 15 and Black at end of Row 17.

Row 20 Ch1, 3dc in first st, skip 1 st, dc in each st and ch-1 sp to last 3-tr group before corner, dc in next st, skip 1 st, 3dc in next st, turn to work down row edge, 38dc evenly across, turn

to work across base, 3dc into ch-sp, (dc into base of 3-tr group, 3dc into ch-sp), rep to end, 3dc in base of last 3-tr group. turn to work down row edge, 38dc evenly across, ss to first dc.

Fasten off and weave in ends.

MITRED SQUARE (MAKE 2)

Using Bright Lime, make a magic loop.

Round 1 (RS) Ch3 (counts as tr throughout), 2tr in loop, ch3, (3tr in loop, ch3) 3 times, ss to top of beg ch-3. [4 3-tr groups, 4 ch-3 sps]

Fasten off.

Join White (White) in any ch-3 sp.

Row 2 (RS) Ch3, 2tr in same sp, ch1, (3tr, ch3, 3tr) in next ch-3 sp, ch1, 3tr in next ch-3 sp, turn. [4 3-tr groups, 1 ch-3 sp, 2 ch-1 sps]

Row 3 (WS) Ch4, 3tr in first ch-1 sp, ch1, (3tr, ch3, 3tr) in ch-3 sp, ch1, 3tr in ch-1 sp, ch1, tr in last st. [2 tr, 4 3-tr groups, 1 ch-3 sp, 4 ch-1 sps]

Change to Black.

Row 4 Ch3, (2tr, ch1) in fist ch-sp, (3tr, ch1) in each ch-1 sp across to corner ch-3 sp, (3tr, ch3, 3tr) in ch-3 sp, (ch1, 3tr) in each ch-1 sp across to final ch-sp, ch1, 3tr in last ch-sp, turn. [6 3-tr groups, 1 ch-3 sp, 6 ch-1 sps]

Row 5 Ch4, 3tr in ch-1 sp, ch1, (3tr, ch1), in each ch-1 sp to corner, (3tr, ch3, 3tr) in corner ch-3 sp, ch1, (3tr, ch1) in each ch-sp to corner, tr in last st. [2 tr, 6 3-tr groups, 1 ch-3 sp, 6 ch-1 sps]

Change to White.

Rows 6-17 Rep Rows 4-5, changing colour every 2 rows alternating between Black and White.

Cont with Black.

Row 18 Ch1, 3dc in first st, dc in each ch-1 sp and st to corner, 3dc in ch-3 sp, dc in each st and ch-1 sp to corner, 3dc in last st, (turn to work across next side, 38dc evenly across) twice, ss to beg dc. [152 dc]

Fasten off and weave in ends.

TO MAKE UP

Refer to the Diagram on page 81 when joining Squares. Using Black, ss the Squares together, working through the bl only.

BORDER

Join Black in corner to work across a long edge.

Round 1 (RS) Ch1 (does not count as st), 3dc in same st, dc to end of first Square, (dc2tog into join, dc to end of Square), rep to corner, 3dc in corner, dc to next corner, 3dc in corner, dc to end of first Square, (dc2tog into join, dc to end

of Square), rep to corner, 3dc in corner, dc to next corner, ss to first dc.

Fasten off and weave in ends.

WRIST WARMERS

Still in denial about the cold? Kelly Wilson Moore's fingerless gloves will keep you feeling warm and looking cool

■ Cygnet DK (100% acrylic, 100g/298m), 1 ball of each: White (208), Black (217), Bright Lime (6869)

■ A 4mm hook (US G/6)

TENSION

10 sts and 4 rows measure 5x5cm (2x2in) over treble crochet using a 4mm hook, or size needed to obtain correct tension

MEASUREMENTS

Wrist Warmers measure approx 18cm (7in) long and 22cm (8¾in) in circumference around hand

NOTES

Wrist Warmers are worked in 2 parts: Wrist and Hand. The Wrist is worked in rows and seamed together. The Hand is worked around the top of the Wrist section in rounds.

Change colour on the final yrh of st before colour change is indicated. Carry the unused colour across the top of your sts, enclosing the strand as you work.

MONOCHROME WRIST WARMERS

RIGHT HAND

WRIST SECTION

Using White, ch21.

Row 1 (WS) Dc in second ch from hook, dc in each ch to end, turn. [20 sts]

Row 2 (RS) Ch1 (does not count as st throughout), dc in each st to end, turn. Change to Black.

Row 3 Ch1, dc in bl of each st to end, turn.

Row 4 Ch1, dc in each st to end, turn.

Change to White.

Rows 5-46 Repeat Rows 3-4, changing colour between Black and White every 2 rows.

Fasten off White and change to Black.

Row 47 Repeat Row 3

Dc the last row to the base of Row 1 to join.

HAND

Continue in Black.

Round 1 (RS) Ch1, 48dc evenly around, ss to beg dc. [48 sts]

Change to Bright Lime.

Round 2 Ch1, dc in each st around, ss to beg dc.

Fasten off Bright Lime and change to Black.

Round 3 Ch3 (counts as tr throughout), tr in each st around, ss to top of beg ch-3. Change to White.

Round 4 Ch3, 23tr, change to Bright Lime, 3tr,



change to White, 21tr, ss to top of beg ch-3.

Change to Black.

Round 5 Ch3, 20tr, change to Bright Lime, 3tr, change to Black, 24tr, ss to top of beg ch-3.

Change to White.

Rounds 6-8 Repeat Row 4-5, then rep Row 4. Change to Black.

Round 9 Ch3, 20tr, change to Bright Lime, 3tr, change to Black, 11tr, ch6, skip 6 sts, 7tr, ss to top of beg ch-3. [42 sts]

Change to White.

Round 10 Ch3, 23tr, change to Bright Lime, 3tr, change to White, 8tr, tr in next 6 ch, 7tr, ss to top of beg ch-3. [48 sts]

Change to Black.

Round 11 Ch3, 12tr, tr2tog, 6tr, change to Bright Lime, 3tr, change to Black, 13tr, tr2tog, 9tr, ss to top of beg ch-3. [46 sts]

Change to White.

Round 12 Ch3, 12tr, tr2tog, 8tr, change to Bright Lime, 3tr, change to White, 10tr, tr2tog, 8tr, ss to top of beg ch-3. [44 sts]

Change to Black.

Round 13 Ch3, 11tr, tr2tog, 5tr, change to Bright Lime, 3tr, change to Black, 12tr, tr2tog, 8tr, ss to top of beg ch-3. [42 sts]

Change to White.

Round 14 Ch3, 11tr, tr2tog, 19tr, tr2tog, 7tr, ss to top of beg ch-3. [40 sts]

Change to Bright Lime.

Round 15 Ch1, dc in each st around, ss to first dc.

Fasten off.

LEFT HAND

WRIST SECTION

Work as Wrist on Right Hand.

HAND

Rounds 1-8 As Rounds 1-8 of Right Hand. [48 sts] Change to Black.

Round 9 Ch3, 6tr, ch6, skip 6 sts, 8tr, change to Bright Lime, 3tr, change to Black, 24tr, ss to top of beg ch-3. [42 sts]

Change to White.

Round 10 Ch3, 6tr, tr in next 6 ch, 11tr, change to Bright Lime, 3tr, change to White, 21tr, ss to top of beg ch-3. [48 sts]

Change to Black.

Round 11 Ch3, 8tr, tr2tog, 10tr, change to Bright Lime, 3tr, change to Black, 10tr, tr2tog, 12tr, ss to top of beg ch-3. [46 sts]

Change to White.

Round 12 Ch3, 8tr, tr2tog, 12tr, change to Bright Lime, 3tr, change to White, 7tr, tr2tog, 11tr, ss to top of beg ch-3. [44 sts]

Change to Black.

Round 13 Ch3, 7tr, tr2tog, 9tr, change to Bright Lime, 3tr, change to Black, 9tr, tr2tog, 11tr, ss to top of beg ch-3. [42 sts]

Change to White.

Round 14 Ch3, 7tr, tr2tog, 20tr, tr2tog, 10tr, ss to top of beg ch-3. [40 sts]

Fasten off White and join Bright Lime.

Round 15 Ch1, dc in each st around, ss to first dc.

Fasten off Bright Lime.

THUMB HOLE

Join Black to Round 8 in st immediately before 6 skipped sts.

Row 1 Ch3, ss in bottom of st above on Round 9, tr in each skipped st, tr in next worked st from Round 8, join with ss in the bottom of st above. [8 sts]

Fasten off.

Join Bright Lime in any st from Row 1.

Round 1 Ch1, work 14dc evenly around thumb opening, ss to beg dc. [14 sts]

Fasten off.

BOTTOM EDGE

Join Black to the bottom edge of Wrist.

Round 1 (RS) Ch1, 48dc evenly around lower edge, ss to beg dc. [48 sts]

Change to Bright Lime.

Round 2 Ch1, dc in each st around, ss to beg dc.

Fasten off and weave in all ends.



MOD GIRL WALL HANGING

Deb Ward's funky wall hanging channels sunshine and bright colour – something the weather has yet to bring us!

- Cygnet DK (100% acrylic, 100g/298m), 2 balls of each: Black (217), White (208), 1 ball of Red (1206)
- A 4mm (US G/6) hook
- Stitch markers
- A dowel, 6mm diameter and approx 50cm long

TENSION

Tension is not critical, but it may affect the yarn quantities required

MEASUREMENTS

Wall Hanging measures approx 42x54cm (16½inx21¼in) excluding fringe

ABBREVIATIONS

tr2d Work a tr in the fl of st 2 rows below
For a full list, see page 78

NOTES

Wall Hanging is worked using the overlay mosaic technique. Work in rows with RS facing throughout. Fasten off at the end of each row and start the next row in the first st of the prev row. Leave long start tails of approx 30cm as these will be incorporated into the fringe. Fasten off with a 15cm tail as these are used to sew the Wall Hanging to the dowel. There is a Chart on page 81, which you should refer to when working the Wall Hanging. Each small square represents a dc worked in the bl and each x represents a tr2d (see Abbreviations). The first square on each row shows the main colour used in that row; either Black or White. All Black rows and most White rows are worked in one colour only. If a second colour appears in that row, it will be filled in with a tr2d on the next row in that colour. However, some White rows will also have Red sts shown. For these sts you will need to change colour to Red when you reach this stitch.

The first few rows of the Chart have been written out to guide you.

All dc sts should be worked into the bl except the first and last st of each row which is worked through both loops.

You can find more information on the overlay mosaic technique here: www.gathered.how/knitting-and-crochet/crochet/how-to-mosaic-crochet/

MOD GIRL WALL HANGING

Using Black, ch112.

Foundation row (RS) Dc in second ch from hook, dc in each across. [111 sts]

Fasten off.

Join Black in first dc.



Row 1 (RS) Ch1 (does not count as st throughout), dc in first st, dc in bl of each st to final st, dc in final st.

Fasten off.

Join White in first st.

Row 2 Ch1, dc in first st, dc in bl of each st to final st, dc in final st.

Fasten off.

Join Black in first dc.

Row 3 Ch1, dc in first st, 30 bl dc, 5tr2d, (1 bl dc, 3tr2d) twice, 7 bl dc, tr2d, (1 bl dc, 3tr2d) twice, (1 bl dc, 2tr2d) twice, (1 bl dc, tr2d) twice, 1 bl dc, 3tr2d, 7 bl dc, 3tr2d, 26 bl dc, dc in final st.

Fasten off.

Join White in first st.

Row 4 Ch1, dc in first st, 2 bl dc, (9tr2d, 3 bl dc) twice, 4tr2d, 5 bl dc, (tr2d, 3 bl dc) twice, tr2d, 5 bl dc, tr2d, 1 bl dc, (tr2d, 3 bl dc) twice, (tr2d, 2 bl dc) twice, (tr2d, 1 bl dc) 3 times, 4 bl dc, 3tr2d, 5 bl dc, 4tr2d, 1 bl dc, change to red, 7 bl dc, change to White, 1 bl dc, 13tr2d, dc in last st.

Rows 5-81 Cont in patt set, using the Chart as you work.

Do not fasten off. Turn work so WS is facing.

Row 82 (WS) Ch1, dc in each st across.

Fasten off.

TO MAKE UP

The panel will need to be carefully blocked before attaching to the dowel rod.

Cut 60cm lengths of each colour. Attach strands to the base of the Wall Hanging using a lark's head knot. Match colours of fringe to the colours of the tails as shown in the image.

Trim fringe to desired length. Using a cutting matt and rotary blade will give a neat finish, but you could use scissors and a ruler.

Tie the end tails around the dowel rod and weave them in on the WS.

Cut 2 lengths of Black, 1m long and hold them together. Tie the ends to the dowel to form the hanging loop.

STRIPY BAG

Less is more when it comes to neon – a balance Claire Fearnley has achieved well with her turquoise-tipped bag

■ Cygnet DK (100% acrylic, 100g/298m), 1 ball of each: Black (217), White (208), Aqua (211)

■ A 4.5mm (US 7) hook

TENSION

Tension is not critical, but it may affect the yarn quantities required

MEASUREMENTS

Bag measures approx 25x23cm (9¾x9in)

ABBREVIATIONS

Hdc2tog (herringbone double crochet 2 together) Insert hook into st, yrh and pull up a

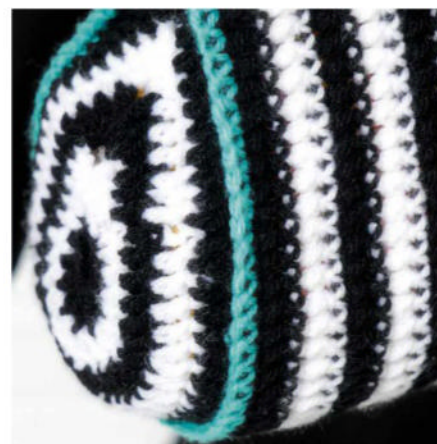

loop, insert hook into next st, yrh and pull up a loop, pull loop through first loop on hook, yrh and pull through 2 loops on hook

For a full list, see page 78

NOTES

Bag is made in 3 pieces: Main Section and 2 Sides. The Main section is worked in rows. The Sides are worked in rounds with RS facing throughout. Parts are joined together with a double crochet seam.

The Upper Edge and Handles are worked around the top of the Bag at the end. Change colour on the final yrh of st before colour change is indicated. Carry the unused colours up the WS of the Bag, ready to use again on the next colour change.

STRIPY BAG

MAIN SECTION

Using Black, ch61.

Row 1 (WS) Dc in second ch from hook, dc in each ch across, turn. [60 sts]

Row 2 (RS) Ch1 (does not count as st throughout), Hdc2tog in first 2 sts, (Hdc2tog beginning in previous st and in next st) rep to end, dc in final st, turn. [59 Hdc2tog, 1 dc]

Change to White.

Row 3 Ch1, dc in each st to end, turn. [60 sts]

Row 4 Ch1, Hdc2tog in first 2 sts, (Hdc2tog beginning in previous st and in next st) rep to end, dc in final st, turn. [59 hdc2tog, 1 dc]

Change to Black.

Rows 5-42 Rep Rows 3-4, changing colour every 2 rows in sequence set.

Fasten off and weave in ends.

SIDES (MAKE 2)

Using Black, make a magic loop.

Round 1 (RS) Ch5 (counts as dtr, ch1), dtr in loop, 10tr in loop, ss to fourth ch of beg ch-5. [2 dtr, 10 tr, 1 ch-sp]

Change to White.

Round 2 Ch3 (counts as tr throughout), (2tr, dtr, ch1, dtr, 2tr) in ch-sp, 3tr, 2tr in next 6 sts, 2tr, ss to top of beg ch-3., changing to Black in ss.

[2 dtr, 22 tr, 1 ch-sp]

Change to Black.

Round 3 Ch3, 3tr, (2tr, dtr, ch1, dtr, 2tr) in ch-sp, 6tr, (2tr in next st, tr in next st) 6 times, 2tr, ss to top of beg ch-3. [2 dtr, 34 tr, 1 ch-sp]

Change to White.

Round 4 Ch3, 6tr, (2tr, dtr, ch1, dtr, 2tr) in ch-sp, 9tr, (2tr in next st, tr in next 2 sts) 6 times, 2tr, ss to top of beg ch-3. [2 dtr, 46 tr, 1 ch-sp]

Change to Black.

Round 5 Ch3, 9tr, (2tr, dtr, ch1, dtr, 2tr) in ch-sp, 12tr, (2tr in next st, tr in next 3 sts) 6 times, 2tr, ss to top of beg ch-3. [2 dtr, 58 tr, 1 ch-sp]

Fasten off and weave in ends.

TO MAKE UP

Work joining with RS facing out.

Join Aqua in first dtr after ch-sp in Side and through first st on last row of Main Section.

Round 1 Ch1, 60dc through Side and Main Section, dc in ch-1 sp in Side only ss to beg dc.

Fasten off.

Join the second Side to the base of Row 1 of Main Section in the same way.

Do not fasten off after joining second Side.

UPPER EDGE AND HANDLES

Work sts evenly across the edges of the stripes at top of the Bag.

Dc3tog will help to avoid gaps at the sides: it is worked into last stripe, side and first stripe at each end of the Bag.

Round 1 (RS) Ch1, *2dc in each colour stripe across front, dc3tog over Side; rep from * once more, ss to beg dc. [86 sts]

Round 2 Ch2 (does not count as st), tr in each st around, ss to first tr.

Change to Black.

Round 3 Ch1, dc in each st to end, ss to first dc.

Round 4 Rep Round 3.

Change to White.

Round 5 Ch1, dc in each st to end, ss to first dc.

Round 6 Ch1, 14dc, ch20, skip 14 sts, 29dc, ch20, skip 14 sts, 15dc, ss to first dc.

[58 dc, 2 ch-20 sps]

Change to Black.

Round 7 Ch1, dc in each st and ch to end, ss to first dc. [98 sts]

Round 8 Ch1, dc in each st to end, ss to first dc
Change to White.

Rounds 9-12 As Round 8, changing to Black at end of Round 10.

Fasten off and weave in ends.

DOTS & DASHES BLANKET

Dot dot dot... dash dash dash... dot dot dot. That's morse code for SOS (save our stitches). Designed by Helen Anderson

■ Cygnet DK (100% acrylic, 100g/298m), 6 balls of Black (217), 5 balls of White (208), 2 balls of Bright Yellow (3378)

■ A 4mm (US G/6) hook

TENSION

Tension is not critical, but it may affect the yarn quantities required

MEASUREMENTS

Blanket measures approx 160x130cm (63x51¼in)

NOTES

Blanket is worked in rows.

There is a Chart on page 81, which you will need to refer to. Each small square represents 1htr. Read all RS rows from right to left and WS rows from left to right. The Chart is repeated 14 times on each row. The first 7 repeats are worked in the first colourway and the second 7 repeat in the second colourway. The first few rows of the Chart have been written out to guide you. Change colour on the final yrh of st before colour change is indicated. Carry the unused colour across the top of your sts, enclosing the strand as you work.

Leave yarn colour on WS of work when last st have been made with that colour.

DOTS & DASHES BLANKET

Using Black, ch225.

Row 1 (RS) Htr in second ch from hook, htr in next 111 ch, change to White, htr in next 112 ch, turn. [224 htr]

Row 2 (WS) Ch1 (does not count as st throughout), 112htr, change to Black, 112htr, turn.

Row 3 Ch1, 112htr, change to White, 112htr, turn.

Row 4 Ch1, 112htr, change to Black, 112htr, turn.

Fasten off White.

Work from Chart from Row 5 onwards.

On RS rows the first 7 repeats use Black as Yarn A, White as Yarn B and Bright Yellow as Yarn C and the last 7 repeats use White as Yarn A, Black as Yarn B and Bright Yellow as Yarn C. On WS rows these are swapped. The colours have been written out in the next 2 rows to guide you.

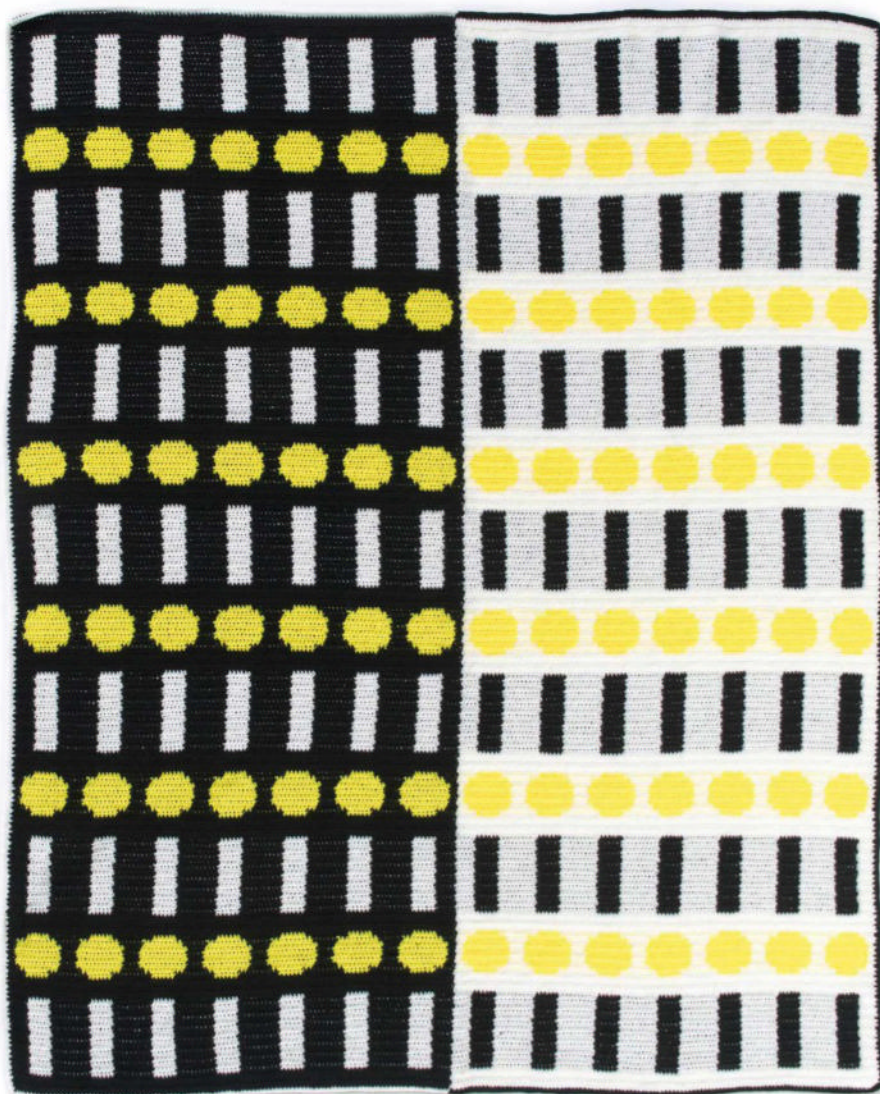

Row 5 Ch1, (5htr, change to White, 6htr, change to Black, 5htr) 7 times, change to White, (5htr, change to Black, 6htr, change to White, 5htr) 7 times, turn.

Row 6 Ch1, (5htr, change to Black, 6htr, change to White, 5htr) 7 times, change to Black, (5htr, change to White, 6htr, change to Black, 5htr) 7 times, turn.

Rows 7-18 Rep Rows 5-6.

Fasten off Bright Yellow.

Row 19 Ch1, 112htr, change to White, 112htr, turn.

Row 20 Ch1, 112htr, change to Black, 112htr, turn.

Rows 21-34 Cont in patt set using the Chart for all colour changes.

Rows 35-202 Rep Rows 5-34, ending on a Row 22 rep.

Fasten off.

BORDER

Join Black in first White st on last row.

Round 1 (RS) Ch1, dc in each st across, ch2, skip corner, (dc in next 2 row-ends, 2dc in next row-end) rep across side, ch2, skip corner, dc in

next 112 sts across bottom, change to White, 112dc, ch2, (1dc in next 2 row-ends, 2dc in next row-end) rep across side, ch2, skip corner, 112dc, change to Black, ss to beg dc.

Round 2 Ch1, *dc in each st to ch-2 sp, (dc, ch2, dc) in ch-sp; rep from * around, changing to White at colour change across base, ss to beg dc.

Fasten off and weave in ends.

GRANNY SQUARE PONCHO

We get it – some days you just want to stay indoors wrapped up in a blanket. Pauline Morgan's poncho is the next best thing!

■ Cygnet DK (100% acrylic, 100g/298m), 3 balls of Yarn A Black (217), 2 balls of Yarn B White (208), 1 ball of Yarn C Jaffa (6632)

■ A 4mm (US G/6) hook

TENSION

14.5 sts and 10 rows measure 10x10cm (4x4in) over granny stitch st using a 4mm hook, or size needed to obtain correct tension

MEASUREMENTS

Each Square before Border measures 38x38cm (15x15in)

See Schematic for Poncho measurements

ABBREVIATIONS

corner dec Work to 3 sts before corner, (insert hook in next st, yrh and pull up a loop) in next 3 sts, skip corner st, (insert hook in next st, yrh and pull up a loop) in next 3 sts, yrh and pull through all sts on hook

standing dc Place slip knot on hook, insert hook in st/sp indicated, yrh and pull up a loop, yrh and pull through 2 loops on hook

invisible join Do not ss to join round, fasten off yarn leaving a 15cm tail and pull live loop, so the tail comes out from the top of the last st. Thread the tail onto a darning needle and insert into the top of the second st of the round, working from RS to WS. Turn so WS is facing, insert needle down the centre of the final st of the round, pull so the loop sitting around the top of the first st matches the tension on the round, weave in end

For a full list, see page 78

NOTES

Poncho is made up of 4 Squares. Squares are worked in rows over the granny stitch pattern. Change colour on the final yrh of row before colour change is indicated. Carry the unused colour up the side of the work. When working the Border on the Squares, work over the carried yarn.

Squares are sewn together, using the images as a guide. A Neckline and Hem are then added.

GRANNY SQUARE PONCHO

BLACK & WHITE SQUARES (MAKE 3)

Using Yarn A, ch58.

Row 1 (RS) Tr in fourth ch from hook (skipped chs counts as tr), (skip 2 ch, 3tr in next ch) 17 times, skip 2 ch, 2tr in last ch, turn. [55 sts]

Row 2 (WS) Ch3 (counts as tr throughout), 3tr in each sp before 3-tr groups across to end, 3tr in sp before final 2 tr, tr in final st, turn. [56 sts] Change to Yarn B.

Row 3 Ch3, tr in sp before first 3-tr group, 3tr in each sp across to sp before final tr, tr in final sp, tr in last st, turn. [55 sts]

Row 4 Ch3 (counts as tr throughout), 3tr in each sp before 3-tr groups across to end, 3tr in sp before final 2 tr, tr in final st, turn. [56 sts] Change to Yarn B.

Rows 5-38 Rep Row 3-4, changing between Yarns A and B every 2 rows.

Fasten off Yarn B.

BORDER

Cont with Yarn A.

Round 1 Ch1 (does not count as st), *(dc, ch2, dc) in first st, (13dc, 2dc in next st) 3 times, 12dc,

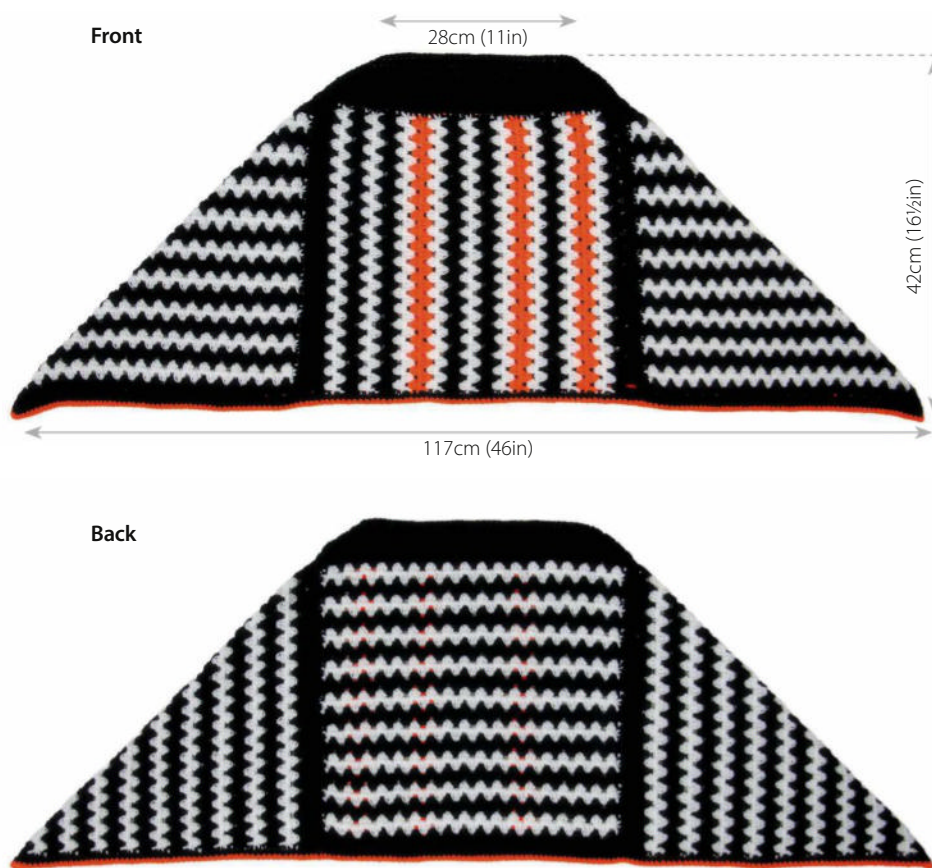

(dc, ch2, dc) in last st, turn to work across row edge, 57dc evenly along side, turn to work across base of Row 1; rep from * once more.

Fasten off Yarn A with invisible join.

ORANGE SQUARE (MAKE 1)

As Black & White Square, changing colour every 2 rows in following sequence: (Yarn A, Yarn B, Yarn C, Yarn B) twice, Yarn A, Yarn B, Yarn A, Yarn B, Yarn C, Yarn B, (Yarn A, Yarn B) twice, Yarn B.

Using Yarn A, worked Border as Blank & White Square.

TO MAKE UP

Join Squares together using Black and a slip stitch seam. Ss working through the bl only. Place Orange Square down flat so that the rows sit vertically. Place a Black & White Square to the side of the Orange Square with the rows sitting horizontally, slip stitch together. Place another Black & White Square to the opposite side of the Oranges Square, again with the rows sitting horizontally, slip stitch together. You will now have a strip of 3 Square with the Orange Square in the centre. Turn the strip over and place the last unjoined Square over the top of the Orange Square, so the stripes sit vertically. Fold the side Squares across the diagonal so the top edge lines up with the sides on the unjoined Square and slip stitch together.

NECKLINE

Place 2 markers at side of neckline opening, in line with corners when Squares are joined.

Join Yarn A with a standing dc in st at centre back of neck.

Round 1 Dc in each st and ch-sp around skipping marked ch-sp, ss to beg dc. [122 sts]

Round 2 Ch3, (tr to 4 sts before marker, corner dec, move marker to last st) twice, tr in each st to end, ss to top of beg ch-3. [110 sts]

Rounds 3-4 As Round 2. [86 sts]

Fasten off.

HEM EDGE

Join Yarn A with a standing dc in st at centre back on lower edge.

Round 1 Dc evenly around working 3dc in each corner on side Squares.

Fasten off with invisible join.

Join Yarn C with standing dc in first st.

Round 2 (Dc in each st to 3-dc inc, dc in next st, 2dc in next st, dc in next st) twice, dc in each st to end.

Fasten off with invisible join and weave in all ends.



YARN STOCKISTS

Cygnat

www.cygnatyarns.com

CIRCULO



**GET THE LOVE
CIRCULO APP**

For Tutorials, Patterns,
Yarn Calculator and
Much More



**NEW TO
UK**

AVAILABLE FROM READICUT, HELLO CRAFTS, AMAZON



SPIKED DC
STITCHES

Electric feel

A boxy boat neck top with wide sleeves,
designed by Chloé Elizabeth Birch



YOU WILL NEED

- Cynet DK (100% acrylic, 100g/298m)
- Yarn A Black (0217)
- Yarn B White (0208)
- Yarn C Bright Pink (6534)
- See table for measurements and yarn quantities
- A 3.5mm (US E/4) hook
- A 3.75mm (US F/5) hook
- Stitch markers
- For yarn stockists contact Cynet Yarns 01274 743374 www.cynet yarns.com

TENSION

18 sts and 9 rows to measure 10x10cm (4x4in) over treble crochet using a 3.75 hook, or size needed to obtain correct tension

ABBREVIATIONS

spiked dc Insert hook in next st 2 rounds below, yrh and pull loop up to height of current round, yrh and pull through 2 loops on hook
For a full list, see page 78

The shape and cut of this garment do the talking, allowing the vivid pink details and raised texture to pop from a distance.

NOTES

Top is worked in rounds from the bottom up. Work then separates into 2 sections at the armhole for the Front and Back. Sleeves are worked separately and sewn to the Top at the end. Change colour on the final yrh of st before colour change is indicated. Carry unused colours up the WS of the work. Instructions are included to change the length of the Top. This might affect the quantity of Yarn A required.

CROP TOP

BODY

Using 3.75mm hook and Yarn A, ch192 (208: 224: 240: 256: 272: 288), ss in last ch from hook to make a loop (being careful not to twist the ch). Pm in the first st of the round, moving it up as you go.

Round 1 (RS) Ch1 (does not count as a st), dc in each ch around, ss to beg dc. [192 (208: 224: 240: 256: 272: 288) sts]

Round 2 (RS) Ch1, dc in each st around, ss to beg dc. Change to Yarn B.

Round 3 Ch1, dc in each st around, ss to beg dc. Change to Yarn A.

Round 4 Ch1, (dc in next st, spiked dc) rep around to end, ss to beg dc. Change to Yarn B.

Rounds 5-12 Rep Rounds 3-4. Cont with Yarn A.

Rounds 13-14 Ch1, dc in each st around, ss to beg dc. Change to Yarn C.

Round 15 Ch1, (1dc, 1hr, 1tr, 2dtr, 1tr, 1hr, 1dc) rep around to end, ss to beg dc.

Round 16 Ch1, dc in each st around, ss to beg dc.



The fabric design features stylish black and white checks and undulating pops of pink

Fasten off Yarn C.

Change to Yarn A.

Round 17 (Working in bl throughout) Ch4 (counts as dtr), (1tr, 1hr, 2dc, 1hr, 1tr, 2dtr) rep around to last 7 sts, 1tr, 1hr, 2dc, 1hr, 1tr, 1dtr, ss to top of beg ch-4.

Rounds 18-19 Ch1, dc in each st around, ss to beg dc.

Change to Yarn B.

Round 20 Ch1, dc in each st around, ss to beg dc.

Change to Yarn A.

Round 21 Ch3 (counts as tr throughout), 2tr, ch1, skip 1 st, (3tr, ch1, skip 1 st) rep around to end, ss to top of beg ch-3.

[144 (156: 168: 180: 192: 204: 216) tr, 48 (52: 56: 60: 64: 68: 72) ch-1 sps]

Change to Yarn B.

Round 22 Ch1, (dc in next 3 sts, dtr in skipped st 2 rows below) rep around to end, ss to beg dc. [192 (208: 224: 240: 256: 272: 288) sts]

Change to Yarn A.

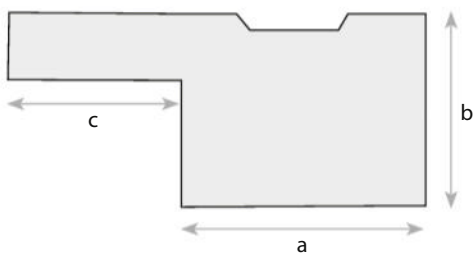

Width a: 51.5 (56: 60.5: 64.5: 69: 73: 77.5)cm, 20¼ (22: 23¾: 25½: 27¼: 28¾: 30½)in
Length b: 42 (44: 46: 48: 50: 52: 53.5)cm, 16½ (17¼: 18¼: 19: 19¾: 20½, 21¼)in
Sleeve length c: 46 (46: 46: 44: 44: 42: 42)cm, 18 (18: 18: 17¼: 17¼: 16½: 16½)in

SIZE		S	M	L	XL	2X	3X	4X
TO FIT BUST	cm	81-86	91-97	102-107	112-117	122-127	132-137	142-147
	in	32-34	36-38	40-42	44-46	48-50	52-54	56-58
ACTUAL BUST (APPROX)	cm	103	112	120.5	129	138	146.5	155
	in	40¾	44	47½	51	54¼	57¾	61
LENGTH	cm	42	44	46	48	50	52	53.5
	in	16½	17¼	18¼	19	19¾	20½	21¼
SLEEVE LENGTH	cm	46	46	46	44	44	42	42
	in	18	18	18	17¼	17¼	16½	16½
YARN A	100g	4	4	5	6	6	7	8
YARN B	100g	1	1	1	2	2	2	2
YARN C	100g	1	1	1	1	1	1	1

To make this pattern easier to follow, we've colour-coded the sizing instructions – simply follow the relevant column.

Round 23 Ch3, 2tr, ch1, skip next st (3tr, ch1, skip next st) rep around to end, ss to top of beg ch-3. [144 (156: 168: 180: 192: 204: 216) tr, 48 (52: 56: 60: 64: 68: 72) ch-1 sps]

Change to Yarn B.

Round 24 Ch1, (dc in next 3 sts, FPttr around skipped st 2 rows below) rep around to end, ss to beg dc.

Rounds 25-30 Rep Rounds 23-24.

Change to Yarn A.

Rounds 31-33 Ch1, dc in each st around, ss to beg dc.

Change to Yarn C.

Rounds 34-36 Rep Rounds 15-17.

Round 37 Ch3, tr in each st around, ss to top of beg ch-3.

Rep last round until Body measures approx 25cm. To change the length of the Top, work more or fewer rows here.

Do not fasten off.

BACK

Cont with Yarn A.

Row 1 (RS) Ch3, tr in next 95 (103: 111: 119: 127: 135: 143) sts, turn leaving rem sts unworked. [96 (104: 112: 120: 128: 136: 144) sts]

Row 2 (WS) Ch3, tr in each st around, turn. Rep last row another 10 (12: 14: 16: 18: 20: 22) times.

Do not fasten off.

RIGHT NECK SHAPING

Row 1 (RS) Ch3, tr in next 26 (29: 32: 35: 38: 41: 44) sts, tr2tog, 1tr, turn. [29 (32: 35: 38: 41: 44: 47) sts]

Row 2 (WS) Ch3, tr2tog, tr in each st to end, turn. [28 (31: 34: 37: 40: 43: 46) sts]

Row 3 Ch3, tr to last 3 sts, tr2tog, tr, turn. [27 (30: 33: 36: 39: 42: 45) sts]

Row 4 Ch3, tr2tog, tr in each st to end, turn. [26 (29: 32: 35: 38: 41: 44) sts]

Rows 5-6 Ch3, tr in each st around, turn. **Fasten off.**

LEFT NECK SHAPING

With RS facing, skip next 36 (38: 40: 42: 44: 46: 48) sts from last full row of Back and join Yarn A in next st.

Row 1 (RS) Ch3, tr2tog, tr in each st to end, turn. [29 (32: 35: 38: 41: 44: 47) sts]

Row 2 Ch3, tr to last 3 sts, tr2tog, tr, turn. [28 (31: 34: 37: 40: 43: 46) sts]

Rows 3-4 As Rows 1-2.

[26 (29: 32: 35: 38: 41: 44) sts]

Rows 5-6 Ch3, tr in each st around, turn. **Fasten off.**

FRONT

Join Yarn A in first unworked st from last round of Body and work as Back.

NECKBAND

Sew the Front and Back together at the shoulders.

With RS facing and using a 3.5mm hook, join Yarn A to left shoulder seam.

Round 1 Ch1, 2dc into edge of each tr row down to centre Front, 34 (38: 42: 46: 50: 54: 58) dc across centre Front, 2dc into edge of each tr row to Back, 34 (38: 42: 46: 50: 54: 58) dc across centre Back, 2dc into edge of each tr row to end, ss to beg dc. [116 (124: 132: 140: 148: 156: 164) sts]

Round 2 Ch1, dc in each st around, ss to beg dc.

Round 3 Ch1, dc in bl of each st around, ss to beg dc.

Change to Yarn C.

Round 4 Rep Round 3.

Fasten off.

SLEEVES (MAKE 2)

Using a 3.75mm hook and Yarn A, ch64 (72: 80: 88: 96: 104: 112), ss in last ch from hook to make a loop (being careful not to twist the ch). Pm in the first st of the round, moving it up as you go.

Rounds 1-37 Work as for Body. Rep last tr round until Sleeve measures 46 (46: 46: 44: 42: 42)cm.



The main body, below the armholes, is seamless as it's worked in the round



Finish the neckband with a single round of bright pink, worked in double crochet

46: 44: 44: 42: 42)cm.

Fasten off.

TO MAKE UP

Sew Sleeves into the armhole opening. Weave in all ends and block to given measurements.

SIMPLE STEPS HOW TO MAKE A TRIPLE TREBLE



1 Yrh 3 times and insert the hook into the stitch indicated. Yrh.



2 Pull the yarn through the stitch (5 loops on hook), *yrh and pull the yarn through the first 2 loops on the hook (4 loops on hook). Repeat from * (3 loops on hook). Yrh.



3 Pull the yarn through the first 2 loops on the hook only (2 loops on hook). Yrh and pull the yarn through the 2 remaining loops.



4 Your finished triple treble stitch should look like this, and you'll have 1 loop left on your hook ready to work the next stitch.



Yarnsmiths Create DK



£2.25 per 100g ball

100% Acrylic

James C Brett Aurora Chunky



£3.99 per 100g ball

80% Acrylic, 20% Wool

Rico Creative Chenillove Sparkle Chunky



£5.99 per 100g ball

100% Polyester

King Cole Flair Chunky



£5.19 per 100g ball

51% Acrylic, 15% Mohair, 15% Polyester, 13% Wool

Sirdar Soft Down DK



£3.99 per 100g ball

80% Acrylic, 20% Wool



FREE DELIVERY on orders over £30



Get 10% OFF EVERYTHING! *
Discount code: SC170

SEE THE ALL NEW YARNSMITHS YARN ON OUR WEBSITE:
www.yarnsmiths.co.uk



Order online: www.woolwarehouse.co.uk
Phone us: 01926 882818 or 0800 505 3300
Email us: hello@woolwarehouse.co.uk

FREE delivery on UK orders over £30

Order online: www.woolwarehouse.co.uk
Phone us: 01926 882818 or 0800 505 3300
Email us: hello@woolwarehouse.co.uk

No minimum order. FREE delivery on UK orders over £30. £2.95 delivery charge for UK orders under £30.
* Discount code not valid on yarn packs and sale items.



MAGNIFICENT MERLIN

This characterful cat will make a purrfect companion. By Wool Couture



YOU WILL NEED

- Wool Couture Cotton Candy (100% cotton, 50g/125m)
2 balls of Black
- A 3.5mm (US E/4) hook
- Toy stuffing
- 2 green safety eyes, 10mm
- Stitch markers

For yarn stockists contact

Wool Couture 01226 414950

www.woolcouturecompany.com

TENSION

Tension is not critical, but it may affect the yarn quantities required

MEASUREMENTS

Cat measures approx 17cm (6¾in) long

ABBREVIATIONS

For a full list, see page 78

Whether new to amigurumi or an old pro, Merlin is sure to charm you with his squishy paws and piercing green eyes.

NOTES

Parts of this pattern are worked using the amigurumi method. Work stitches continuously in a spiral without closing off each round with a slip stitch. It may help to use a stitch marker in the first stitch of each round, moving it up as you work.

If you are making this as a toy for a child under 36 months, do not use safety eyes; instead, embroider eyes using green stranded cotton. Refer to images when joining parts together.

BLACK CAT

HEAD

Make a magic loop.

Round 1 (RS) Ch1 (does not count as st throughout), 6dc in loop. [6 sts]

Round 2 (RS) 2dc in each st around. [12 sts]

Round 3 Dc in each st around.

Round 4 (1dc, 2dc in next st) 6 times. [18 sts]

Round 5 Dc in each st around.

Round 6 (2dc, 2dc in next st) 6 times. [24 sts]

Pm after the first inc to mark the centre top of the Head.

Round 7 (3dc, 2dc in next st) 6 times. [30 sts]

Round 8 (2dc in next st, 1dc) 5 times, 18dc, 2dc in next st, 1dc. [36 sts]

Rounds 9-10 Dc in each st around.

Round 11 (5dc, 2dc in next st) 6 times. [42 sts]

Round 12 Dc in each st around.

Round 13 (6dc, 2dc in next st) 6 times. [48 sts]

Rounds 14-17 Dc in each st around.

Using the marker on Round 6 as a guide, place eyes between Rounds 9-10, approx 7 sts apart.

Round 18 (6dc, dc2tog) 6 times. [42 sts]

Round 19 (5dc, dc2tog) 6 times. [36 sts]

Round 20 (4dc, dc2tog) 6 times. [30 sts]

Stuff as you go.

Round 21 (3dc, dc2tog) 6 times. [24 sts]

Round 22 (2dc, dc2tog) 6 times. [18 sts]

Round 23 (1dc, dc2tog) 6 times. [12 sts]

Round 24 (Dc2tog) 6 times. [6 sts]

Fasten off.

Thread tail through fl of final 6 sts and pull tight to close.

Using Black, embroider a nose.

BODY

Make a magic loop.

Round 1 (RS) Ch1, 6dc in loop. [6 sts]

Round 2 2dc in each st around. [12 sts]

Round 3 (1dc, 2dc in next st) 6 times. [18 sts]

Round 4 (2dc, 2dc in next st) 6 times. [24 sts]

Round 5 (3dc, 2dc in next st) 6 times. [30 sts]

Round 6 (4dc, 2dc in next st) 6 times. [36 sts]

Round 7 (5dc, 2dc in next st) 6 times. [42 sts]

Round 8 (6dc, 2dc in next st) 6 times. [48 sts]

Round 9 (7dc, 2dc in next st) 6 times. [54 sts]

Round 10 (8dc, 2dc in next st) 6 times. [60 sts]



Test the position of the legs before stitching them to the body

Rounds 11-15 Dc in each st around.

Round 16 (8dc, dc2tog) 6 times. [54 sts]

Rounds 17-18 Dc in each st around.

Round 19 (7dc, dc2tog) 6 times. [48 sts]

Rounds 20-21 Dc in each st around.

Round 22 (6dc, dc2tog) 6 times. [42 sts]

Rounds 23-26 Dc in each st around.

Round 27 (5dc, dc2tog) 6 times. [36 sts]

Rounds 28-30 Dc in each st around.

Round 31 (4dc, dc2tog) 6 times. [30 sts]

Round 32 Dc in each st around.

Round 33 (3dc, dc2tog) 6 times. [24 sts]

Round 34 Dc in each st around.

Fasten off, leaving a long tail.

Stuff the Body and sew Head to the final round.

BACK LEGS (MAKE 2)

Make a magic loop.

Rounds 1-5 As Rounds 1-5 of Body. [30 sts]

Rounds 6-9 Dc in each st around.

Round 10 7dc, (dc2tog) 8 times, 7dc. [22 sts]

Round 11 7dc, (dc2tog) 4 times, 7dc. [18 sts]

Round 12 7dc, (dc2tog) twice, 7dc. [16 sts]

Stuff foot and lightly stuff Legs to the halfway point. Leave the upper Legs unstuffed.

Rounds 13-29 Dc in each st around.

Flatten final round and ss across to close.

Fasten off, leaving a long tail.

Sew Back Legs to the Body.

TAIL

Make a magic loop.

Round 1 Ch1, 4dc in loop. [4 sts]

Rounds 2-30 Dc in each st around.

Fasten off.

Sew the Tail onto the back of the Body, over Rounds 11-12.

FORELEGS (MAKE 2)

Make a magic loop.

Rounds 1-4 As Rounds 1-4 of Body. [24 sts]

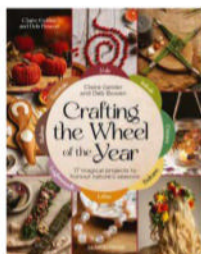

This pattern is taken from *Crafting the Wheel of the Year* by Claire Gelder and Deb Bowen (Search Press £15.99)



Will a toddler be playing with this adorable kitty? If so, replace safety eyes with embroidery

Rounds 5-8 Dc in each st around.

Round 9 6dc, (dc2tog) 6 times, 6dc. [18 sts]

Round 10 6dc, (dc2tog) 3 times, 6dc. [15 sts]

Stuff hand and lightly stuff Forelegs to the halfway point. Leave upper Forelegs unstuffed.

Rounds 11-26 Dc in each st around.

Ss across to close the opening.

Fasten off leaving a tail of yarn to sew to Body.

Sew the Forelegs onto each side of the Body in between the neck and the Body.

dc in next 6 ch, turn. [7 sts]

Row 2 Ch1, dc2tog first 2 sts, dc in each st to end, turn. [6 sts]

Rows 3-6 As Row 2. [2 sts]

Row 7 Ch1, dc2tog.

Fasten off first 2 pieces only.

Place 2 pieces together, with RS facing out and work next round through both pieces to join.

Round 8 Ch1, 7dc across each side, ss to beg dc.

Fasten off.

Sew Ears to Round 16 of Head, approx 7 sts apart.

EARS (MAKE 4)

Row 1 Ch8, dc into second ch from the hook,

SIMPLE STEPS HOW TO JOIN AMIGURUMI PARTS



1 Thread the yarn onto a tapestry needle. Secure the yarn to one piece with a small stitch. Insert the needle into the second piece where you wish to make the join.



2 Insert the needle through the first piece and back out. Next work through the second piece in the same way.

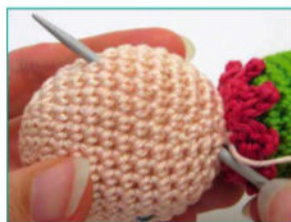

3 Repeat Step 2 until the pieces are securely joined. Insert the needle through and out at the back of one piece.



4 Weave the final tail inside one of the pieces.

Simply Crochet

SAVE TIME, MONEY AND HASSLE WITH AN ANNUAL *SIMPLY CROCHET* SUBSCRIPTION



- Download the latest issue straight away
- Get a further 12 issues in your first year
- All issues download automatically
- Download it once... read it offline forever



iPad is a trademark of Apple Inc., registered in the U.S. and other countries. App Store is a service mark of Apple Inc. NOOK is a registered trademark of Barnes & Noble, Inc. NOOK Tablet is a trademark of Barnes & Noble, Inc



To subscribe simply visit:

www.ourmediashop.com/simply-crochet-magazine

The digital version of the magazine does not include the cover gift that you would find on newsstand copies



Yarn, free patterns
and accessories
at Hobbii.com

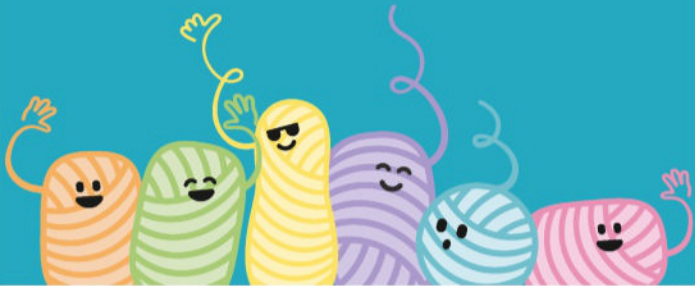

The
Possibilities
are
Endless



Recycle your magazine and seven days
later it could come back as your newspaper

www.recyclenow.com



TRULLY WOOL RICH 4-PLY

Trully Wool Rich 4 Ply is a hard wearing four ply yarn, perfect for fine garments and sock knitting.

The 25% Polyamide content gives it added strength, yet the yarn has a soft handle with a lasting quality and will keep its quality through repeated machine washing.



FABULOUS QUALITY, SENSIBLY PRICED. WWW.CYGNETYARNS.COM OR CALL 01274 743374



FUR REAL

Fallen out of love with your hoodie? Jess Bennett's faux fur trim will totally transform your style



YOU WILL NEED

- Yarnsmiths Zooaura (100% polyester, 50g/30m)
3 balls of Leopard Print (4B700)
- A 10mm (US N/15) hook
- A hooded sweatshirt
- A sewing machine or sewing needle and thread

For yarn stockists contact
Wool Warehouse 01926 882818
www.woolwarehouse.co.uk

TENSION

7 sts and 5 rows measure 10x10cm (4x4 in) over double crochet using a 10mm hook, or size needed to obtain this tension

MEASUREMENTS

Neck Tie measures approx 180x7cm (71x2¾in)
Hood trim measures 80x5cm (31½x2in)

ABBREVIATIONS

For a full list, see page 78

This easy upcycling hack boasts not one but two benefits: it protects against the cold and makes you look (and feel) fabulous.

NOTES

The Neck Tie and Hood Trim are worked in rows of dc. The Trim is sewn onto the hood around the front opening and the Neck Tie is sewn onto the base of the hood. There is no right or wrong side.

This pattern will fit a hood with a front opening of 80cm. To adjust the length of the trim work enough sts to fit the opening (each st is approx 1.4cm).

HOODIE UPCYCLE

PREPARE THE HOODED SWEATSHIRT

To prepare the hooded sweatshirt, carefully cut the hood off just above the neckline so that the rest of the sweatshirt can be worn as it is or used for another upcycle project.

Finish the cut edge by using a zigzag stitch on a sewing machine, hand-sewing a blanket stitch, or folding up and stitching to create a hem.

NECK TIE

Ch2.

Row 1 3dc into second ch from hook, turn. [3 dc]

[3 dc]

Row 2 Ch1 (does not count as st throughout), 2dc in first st, 1dc, 2dc in last st, turn. [5 dc]

Rows 3-92 Ch1, 5dc, turn.

Row 93 Ch1, dc2tog, 1dc, dc2tog, turn. [3 sts]

Row 94 Ch1, dc2tog over first 2 sts, dc2tog over sts 2 and 3, working the first leg into the same st as previous st. [2 sts]

Fasten off and weave in ends.

HOOD TRIM

Make a chain to the length of the opening of hood. We worked a ch51.

Row 1 Dc in second ch from hook, dc in each ch across, turn.

Row 2 Ch1, dc in each st across.

Fasten off and weave in ends.

TO MAKE UP

Pin Hood Trim around outside of the hood opening, lining up the ends with the bottom corners of the hood and with the trim approx 1cm over the edge of the hood. Sew into place. Fold the Neck Tie in half to find the centre. Pin the centre to the centre-back of the hood and then pin along the edge to the bottom corners and sew securely in place.

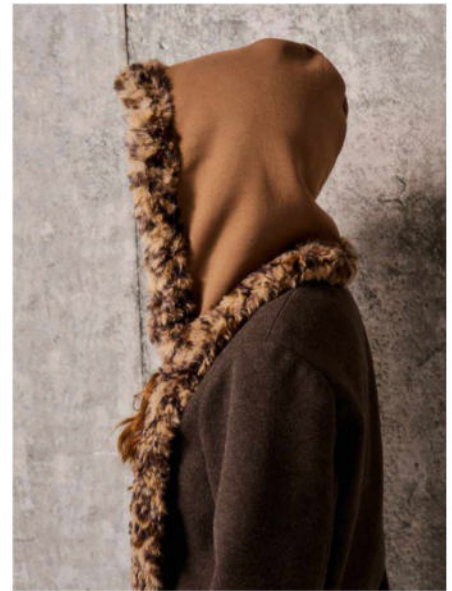

Both pieces are crocheted as long, thin strips and sewn onto the sweatshirt's hood

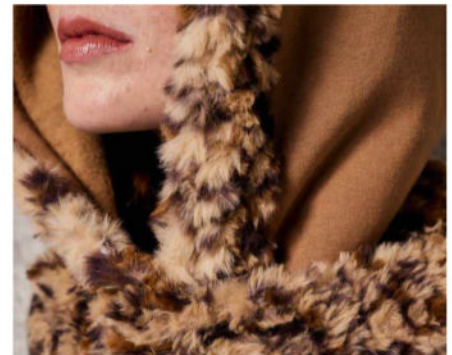

Prepare the hood by securing the cut edges with a machine stitch or by hand sewing

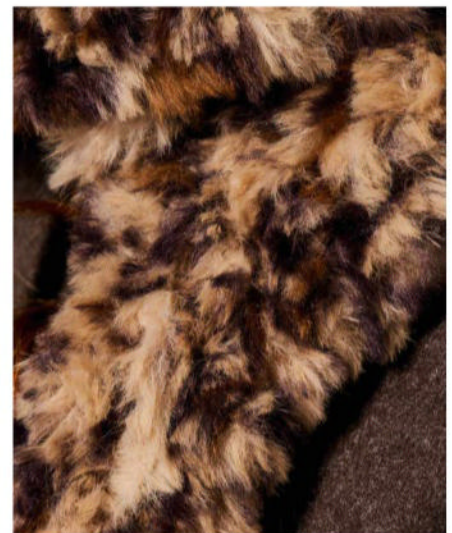

This furry effect is created entirely by the yarn structure, which has a thick, hairy texture



RICO CHINGUS



In our brand new Ricorumi pattern booklet Rico Chingus discover 19 patterns for super-cool accessory charms. Chingu is the Korean word for friends and we show you how to crochet trendy charms that are a cool fashion statement on bags, to give your keys or jewellery a personal touch. Our Rico Chingus are crocheted with our popular yarns Ricorumi dk, Ricorumi Nilli Nilli and Ricorumi Furry Furry. The best: we have three crochet kits with all the materials needed. Visit your favourite store and discover our Rico Chingus. Available 22nd January 2026!



PROUD TO SUPPORT YOUR YARN SHOP

follow us on





LUSH LILIES

Maria Jęczmyk's blanket is a blooming lovely project to kickstart your new year



YOU WILL NEED

- Scheepjes Terrazzo
(70% wool, 30% viscose, 50g/175m)
23 balls of Piuma (740)
4 balls of Sabbia (746)
- A 4mm (US G/6) hook
- Stitch markers

For yarn stockists contact

Scheepjes www.scheepjes.com/en

TENSION

6x6 c2c blocks measure 10x10cm
using a 4mm hook or size needed
to obtain tension

MEASUREMENTS

Blanket measures approx
156x185cm (61½x73in)

ABBREVIATIONS

c2c block Ss in next ch-3 sp, ch3,
3tr in same sp

For a full list, see page 78

The history of Zakopane style

My lily blanket was inspired by Polish Zakopane style, which is most visible in architecture, but can also be seen in furniture and household objects. It was brought about in the 19th century by Stanisław Witkiewicz, who helped distinguish Polish art from Swiss alpine style. One of the most popular decorative motifs of Zakopane style is the martagon lily, or 'leluja'. Leluja was often carved in wood to decorate stairs, doors and furniture, and you could also find it on fabric and pottery. It is a small, delicate motif – the c2c blanket required an upscaled version.

Words by Maria Jęczmyk

Flowers may be in short supply outside at the moment, but this lily motif blanket will guarantee year-round florals in your home.

NOTES

Blanket is worked using the corner-to-corner (c2c) method. Each row is worked diagonally, starting with 1 c2c block (see abbreviations) in the first row, increasing to 2 blocks in the next row, 3 blocks in the next row, and so on. For the central section the number of c2c blocks remains the same. For the decreasing rows, the number of c2c blocks decreases by one block each row.

Change colour on the ss at the start of each c2c block. If colour changes are 1-5 blocks apart, carry the unused colour and enclose in the sts as you work. When colour changes are more than 5 c2c blocks apart, leave the yarn on the WS of your work ready to pick up again on the next row. In this case, you should use a separate ball of each colour for each section of colour. There is a Chart on page 80, which you will need to refer to. Each small square represents 1 c2c block. Read all RS rows from right and up to the left, and WS rows from left and down to the right. The first few rows of the Chart have been written out to guide you.

C2C BLANKET

INCREASING ROWS

Using Piuma, ch6.

Row 1 (RS) Tr in fourth ch from hook and next 2 ch, turn. [1 c2c block]

Row 2 (WS) Ch6, tr in fourth ch from hook and next 2 ch (counts as first block throughout), c2c block in ch-sp on next block, turn. [2 c2c blocks]

Row 3 (RS) Ch6, tr in fourth ch from hook and next 2 ch, c2c block in each ch-sp across, turn. [3 c2c blocks]

Rows 4-22 As Row 3.
[22 c2c blocks at end of Row 22]

Row 23 Ch6, tr in fourth ch from hook and next 2 ch, c2c block in next 11 ch-sp, change to Sabbia, c2c block in next ch-sp, change to Piuma, c2c block in next 10 ch-sp, turn. [23 c2c blocks]

Rows 24-97 As Row 3, using the Chart for all colour changes. [97 c2c blocks]

STRAIGHT ROWS

Cont using the Chart for colour changes.

Row 98 Ch6, tr in fourth ch from hook and next 2 ch, c2c block in each ch-3 sp to final ch-3 sp, ss into block, turn leaving last sp unworked. [97 c2c blocks]

Row 99 Ss in 3 tr of last row to first ch-sp, c2c block in each sp across to end, turn.

Rows 100-110 Rep Rows 98-99, ending on a Row 98 rep.

DECREASING ROWS

Row 111 Ss in 3 tr on last row to first ch-sp, c2c



Add a border in double crochet to create slimline stripes worked over three rounds



The corner to corner technique creates a textured, open stitch fabric with a soft drape

block in each ch-3 sp to final ch-3 sp, ss into ch-sp, turn leaving last sp unworked.
[96 c2c blocks]

Rows 112-206 As Row 111. [1 c2c]
Do not fasten off.

BORDER

Cont with Piuma.

Round 1 (RS) Ch1, dc evenly around edges, working 3dc in each block and 3dc in each corner (pm in second dc in each corner), ss to beg dc to join.

Change to Sabbia.

Round 2 (RS) Ch1, (dc in each st to marker, 3dc in marker) rep around, ss to beg dc.

Change to Piuma.

Round 3 As Round 2.

Fasten off and weave in ends.



For a more luxurious make, try Rowan Felted Tweed: 23 balls of Clay (177), 4 balls of Mineral (181). Check hook size, tension and ball length if you use a different yarn.

For yarn stockists contact
www.knitrowan.com

New leaf

Jane Howarth's cute book cosy will help you stick to your literary resolutions this year

PRETTY
APPLIQUÉ





YOU WILL NEED

- Lang Yarns Yak
(70% Merino extrafine virgin wool, 30% yak, 50g/120m)
1 ball of each:
Atlantic (0074)
Bronze (0011)
- Lang Yarns Noelle
(79% Merino extrafine virgin wool, 21% nylon, 25g/185m)
1 ball of each:
Jade (0073)
Brick (0087)
Nougat (0015)
Brown (0068)
Mud (0099)
- A 5mm (US H/8) hook
- A 3mm (US C/2 or D/3) hook
- 2 buttons, 2cm

For yarn stockists contact
McIntosh
www.knitmcintosh.com

TENSION

15 sts and 16 rows measure 10x10cm (4x4in) over double crochet using a 5mm hook, or size needed to obtain correct tension

MEASUREMENTS

Book Cover measures approx 27x19cm (10½x7½in)

ABBREVIATIONS

For a full list, see page 78

These fine natural fibres offer excellent stitch definition, ideal for detail-driven appliqués and delicate embroidery.

NOTES

Book Cover is made up of 2 Panels. The initial rounds of the Bird Motif are worked using the amigurumi method. Work stitches continuously in a spiral without closing off each round with a ss. It may help to use a marker in the first st of the round, moving it up as you go. Refer to images for the embroidery and appliqué placement, or embellish as preferred. You can find full embroidery tutorials here: www.gathered.how/needlework/embroidery/library-of-embroidery-stitches-for-beginners

BOOK COVER

PANELS (MAKE 2)

Using a 5mm hook and Atlantic, ch41.

Row 1 (RS) Dc in second ch from hook and each ch across, turn. [40 sts]

Row 2 (WS) Ch1 (does not count as st throughout), dc in each st across, turn.

Rows 3-32 Rep Row 2.

Change to Bronze.

Row 33 Ch1, dc in each st across.

Fasten off.

BIRD MOTIF

Using a 5mm hook and Bronze, make a magic loop.

Round 1 (RS) Ch1, 6dc into loop. [6 sts]

Round 2 (RS) 2dc in each st around. [12 sts]

Round 3 (2dc in next st, dc in next st) 6 times, ss to first st, turn. [18 sts]

Round 4 (WS) Ch1, (ss, 3dc) in next st, ss in next st, turn. [5 sts]

Round 5 Ch1, 2dc in next 3 sts, ss in next st. [7 sts]

Fasten off, leaving a long tail.

SMALL FLOWERS/LEAVES (MAKE 13)

Make 6 in Brick, 2 in Nougat and 5 in Jade.

Using a 3mm hook, make a magic loop.

Row 1 (RS) Ch1, 3dc into loop, turn. [3 sts]

Row 2 (WS) Ch2 (counts as htr throughout), 2htr in next st, htr, turn. [4 sts]

Row 3 (Ch4, tr in third ch from hook, tr in next ch, ss in next st of Row 2) 3 times. [3 petals]

Fasten off, leaving a long tail.

LARGE RED FLOWERS (MAKE 3)

Using a 3mm hook and Brick, make a magic loop.

Row 1 (RS) Ch1, 3dc into loop, turn. [3 sts]

Row 2 (WS) Ch2, htr in next 2 sts, turn.

Row 3 Ch2, htr in st at base of ch-2, htr in next st, 2htr in last st, turn. [5 sts]

Row 4 Ch2, htr in each st across, turn.

Row 5 Ch2, htr in st at base of ch-2, 2htr in next st, htr in next st, 2htr in last 2 sts, turn. [9 sts]

Row 6 (Ch5, htr in third ch from hook, htr in next ch, tr in next ch, skip 1 st in Row 5, ss in

next st) 4 times. [4 petals]

Fasten off, leaving a long tail.

SHORT VINES (MAKE 2)

Using a 3mm hook and Jade, make a slip knot.

Row 1 *Ch1, (ch4, tr in third ch from hook, tr in next ch, ss in beg ch-1), 3 times, ch5, rep from * once more.

Fasten off, leaving a long tail.

LONG VINES (MAKE 2)

Using a 3mm hook and Jade, make a slip knot.

Row 1 *Ch1, (ch4, tr in third ch from hook, tr in next ch, ss in beg ch-1), 3 times**, ch9, rep from * to ** once more, ch5.

Fasten off, leaving a long tail.

BUTTERFLIES (MAKE 2)

Using a 3mm hook and Mud, ch5.

Row 1 (RS) Dc in second ch from hook and each ch across, turn. [4 sts]

Row 2 Ch4, ss in second ch from hook, htr in next ch, tr in next ch, (ss, ch2, htr, tr) in next st, (tr, dtr) in next st, ch3, ss in last st, rotate to work along opposite side of foundation ch, (ss, ch3, dtr, tr) in first st, (tr, htr) in next st, ch2, ss in next st, ch4, starting in second ch from hook, ss, htr, tr, ss in last st.

Fasten off, leaving a long tail.

LOOPS (MAKE 2)

Using 5mm hook and Bronze, ch22.

Fasten off, leaving a long tail.

Sew buttons into sts 13 and 28 of Rows 27-28 of one Panel to make front. Sew ends of Loops to inner edge of second panel in sts 12 and 14, and sts 27 and 29 to create 2 button loops This makes the back. Sew appliqués to front Panel.

EMBROIDERY

Using Bronze, embroider tail detail onto Bird, using long stitches worked close together and overlapping if preferred, for bolder texture. Using Brown, embroider wings onto the Bird, using long stitches from head outwards. Using Mud, add feather details to wing, tail and body, and fanning out across neck. Using Bronze, create legs in 2 stitches, with a horizontal stitch to create feet. Using Nougat, embroider 4 sts into a point to form beak. Using Brown, embroider an eye.

Using Brown, create Butterfly body with overlapping, long stitches between wings, and antennae with 2 stitches at the top of the body. Embellish wings as desired.

Finish Small Flowers using Jade to create a stem, extending in the style of a fan stitch at base of Small Flower.

TO FINISH

Sew up 3 sides of Book Cover, leaving button edge open. Weave in all ends.

Bundle up

Susan Pearson's wide panelled scarf works up a treat for confident crocheters

STYLISH
TRIM





YOU WILL NEED

- DROPS Nepal
(65% wool, 35% alpaca, 50g/75m)
5 balls of Chalk (8915)
4 balls of Red Clay (8914)
 - A 7mm (US K10½ or L/11) Tunisian hook with short extension cable
- For yarn stockists contact**
Wool Warehouse 01926 882818
www.woolwarehouse.co.uk

TENSION

14 sts and 12 rows measure 10x10cm (4x4in) over Arrowhead st using a 7mm hook, or size needed to obtain correct tension

MEASUREMENTS

Scarf measures approx 196x33cm (77x13in)

ABBREVIATIONS

Tfs (Tunisian foundation stitch) Insert hook in next ch, yrh and pull up a loop, leave loop on hook
Tss (Tunisian simple stitch) Insert hook through bar on next st from right to left, yrh and pull up a loop, leave loop on hook
RetP (return pass) Ch1, (yrh, pull through 2 loops on hook) rep to end
Tss3tog Insert hook through next 3 bars from right to left, yrh and pull up a loop, leave loop on hook
Tfulls (Tunisian full stitch) Insert hook through work from RS to WS to left of bar on next st, yrh and pull up a loop, leave loop on hook
Tfulls-dc Yrh, insert hook through work from RS to WS to left of bar on next st, yrh and pull up a loop, yrh and pull through 2 loops on hook
Trs (Tunisian reverse stitch) Insert hook through bar of next st on WS (from right to left), yrh and pull up a loop, leave loop on hook
end st Insert hook under the last bar of the row and the bar that lies behind it, yrh, pull up loop
yrh Wrap yarn around hook and leave in place when working the next st, this counts as an increase
 For a full list, see page 78

A warm terracotta shade evokes visions of a cosy fireside glow. With a blend of wool and alpaca, you'll hardly feel the cold this winter.

NOTES

Scarf is worked in 2 Panels and sewn together. Both Panels are worked in the Tunisian style. Each Tunisian row is worked in 2 parts. The forwards pass (FwdP) is worked from right to left picking up a loop in each st. When working into the final st of a row, insert the hook through both loops on the edge of work. The return pass (RetP) is worked from left to right removing each loop from the hook. The loop on the hook at the start of each row counts as the first st throughout. When colour change is indicated, change colour on the final yrh on the RetP to begin the next row in the new colour. Work with RS facing throughout.

TUNISIAN SCARF

PANELS (MAKE 2)

Using Red Clay, ch44.
Foundation row Tfs in bl of second ch from hook, Tfs in bl of each ch across (44 loops on hook), RetP across. [44 sts]
 Change colour to Chalk.
Row 1 (Yrh, 5Tss, Tss3tog, 5Tss, yrh, 1Tss) 3 times, end st (44 loops on hook), RetP across. Change colour to Red Clay.
Row 2 (Yrh, 1Tfulls, 4Tss, Tss3tog, 4Tss, 1Tfulls, yrh, 1Tss) 3 times, end st (44 loops on hook), RetP across.
 Change colour to Chalk and cont to change colours at the end of every RetP throughout.
Rows 3-6 Repeat Row 2.
Row 7 *1Tfulls, 4Tss, 1Tfulls-dc, ch1, 1Tfulls, ch1, 4Tss, 1Tfulls, 1Tss; rep from * twice more, end st (44 loops on hook), RetP across.
Row 8 Tss in each st across, end st, RetP across.
Row 9 Trs in each st across, end st, RetP across.
Rows 10-11 Rep Rows 8-9.
Row 12 (Tss2tog, yrh) 21 times, end st (44 loops on hook), RetP across.
Row 13 (1Tss, 1Tfulls) 21 times, end st (44 loops on hook), RetP across.
 Rep Rows 12-13 until Panel measures approx 95cm long, ending on a Row 13 rep. Cont with Chalk.
Next row Ss in bar of each st across.
Fasten off.

TO MAKE UP

Weave in all ends and block each Panel. Sew the Panels together across the final row using a mattress stitch.



Work the scarf in two panels and seam them together along the final row of each piece



The zigzag border, made up of seven rows, is worked first – the remaining rows are straight

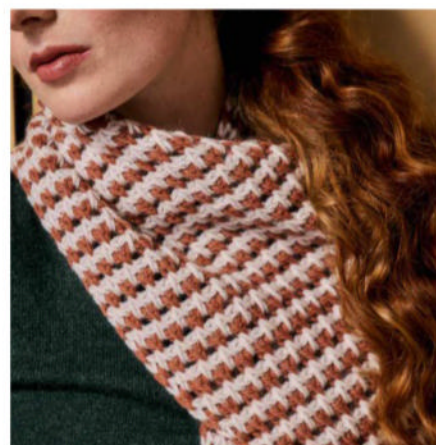

This scarf pattern utilises several Tunisian crochet stitches for you to practise on



Amber's crochet skills came into their own when she started designing her own colourwork patterns

COLOUR ME INSPIRED

Artsy Amber has always loved creating, and it was one fateful stint in a yarn shop that led to designing her own fabulous colourwork

Learning to crochet is a process of trial and error for many of us. A struggle with hook and yarn can lead us to believe it's not our thing, and we stick rigidly to other hobbies. But for crochet designer Amber Millard, it's not an either/or situation. Despite not taking to crochet until her 20s, her love for drawing, painting and doodling, harking back to her childhood, has had a profound influence on her crochet style.

Amber learnt the basics from her mother when she was around seven years old. "I'm pretty sure I wanted to make a blanket with one skein of Red Heart Super Saver and a 4mm hook," she reflects. "As you can imagine, that didn't turn out well." Further attempts were made, but it wasn't until her mid-20s that Amber truly caught the crochet bug. "I worked at a craft store and all that

pretty, pretty yarn started whispering to me. By then YouTube was a thing and with my little bit of prior knowledge, I was able to pick it up quickly and started following every pattern I could find online."

Crochet is a broad medium, and no two crafters have the same experience. What draws one person in can have the opposite effect on another. Some like granny squares, chain spaces and lacy drapes, while others are partial to a firmer fabric, like mosaic crochet. For Amber, it was colourwork that really appealed to her.

"I like to call it 'painting with yarn' because during the design process, it reminds me a lot of how I'd approach drawing or painting," she explains. "Making a mess, finding a style that works for me, and lots of erasing (frogging)." In fact, the way Amber works with yarn and hooks mirrors how she works

with pencil and paper: "It's a pretty active process for me. I'd have sketches of the same thing on four pages until I liked how it looked."

INSPIRATION EVERYWHERE

As she became more confident as a designer, and got a feel for what styles and techniques she enjoyed, Amber started her blog, *Divine Debris*. It's a treasure trove of striking motifs that channel her signature cosy, spooky vibes. "My most popular pattern by a long shot is my Glenda Ghost Bag," she remarks fondly. "The response to that was incredible, and I think I'll be chasing that high for the rest of my crochet career."

She's also designed patterns for Pride Month, which are available all year round, with discounts and new designs released in June. During this time, the proceeds are donated to LGBTQ+ charities like The Trevor

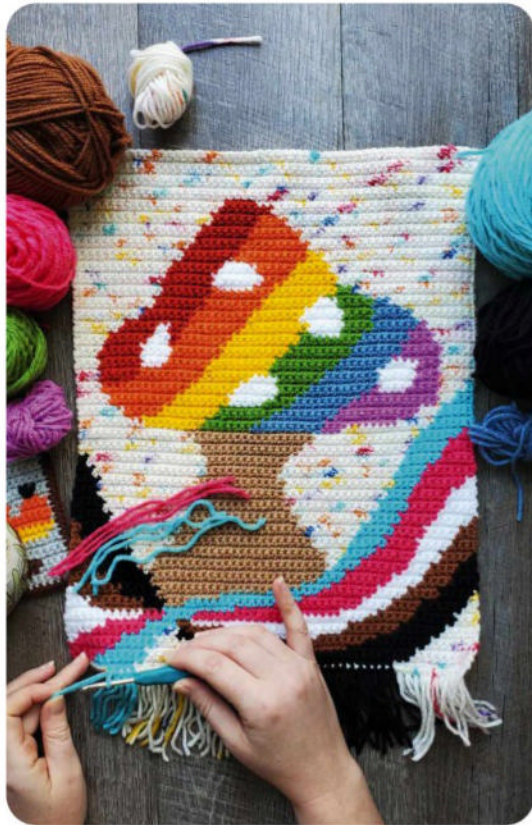

Project and Trans Lifeline. “As a queer woman myself, this is an issue close to my heart,” she says. “I’m glad I can do what I can.”

Amber’s blog also rounds up patterns from other designers, grouped by occasions such as Halloween, Christmas and Valentine’s Day. “It’s fun to share the work of other people with my followers. There are so many crocheters, knitters and designers I just adore!” @tlyarncrafts, @crochethighway and @thedreamcrochet are a few of her major inspirations. “Recently I got to see @crochet.or.cry’s book,” she adds. “As a fellow tapestry crochet lover, it blew me away.”

So what inspires Amber’s own designs? “I try to draw inspiration from everything,” she tells us, “from the world around me to holidays (especially Halloween, as it’s my favourite).” A peek at her autumn-hued jumpers, skull-emblazoned cardigans and ghostly granny squares is a case in point. “One of my biggest inspirations is my mood,” she adds. “I struggle to design or create when my heart isn’t in it.”

DIGITALLY DIVINE

Crafting has been a mainstay in Amber’s life for over a decade now, and she’s quick to point out the mental health benefits. “Crochet as both an art form and meditative practice just seemed so appealing. I can’t believe there was a time I wasn’t crocheting, or at least had my ‘emotional support skein’ in my bag with me.” How does the slow, mindful nature of crochet stack up against

the pressure of maintaining an online presence? “I have such a love-hate relationship with social media,” Amber admits, “but I try to maintain a feed that inspires me. Sometimes I get a little jealous and wish I could be more creative, successful, professional – you name it. But right now I’m really happy following cool people who make cool stuff.”

“I CAN’T BELIEVE THERE WAS A TIME I WASN’T CROCHETING, OR AT LEAST HAD MY ‘EMOTIONAL SUPPORT SKEIN’ IN MY BAG”

With YouTube helping her get to grips with crochet, and an uplifting community on social media, it’s fair to say *Divine Debris* embraces the digital world. But like many fibre artists, Amber knows exactly where she draws the line. “I really want to make a design that makes it clear my stance on AI,” she says.

“I feel like we’re just beginning to see the effects of AI slop in fibre arts spaces, with fake photos and patterns eroding the confidence in indie designers. It just kills me to see how much damage AI is doing.”

TRUE TO FORM

What really stands out about *Divine Debris* is Amber’s sense of self. Her designs – whether that’s a bag with steaming coffee cup motifs, or a wall hanging of rolling hills – convey a sense of human uniqueness that defies the artificial and celebrates authenticity.

“I try to make things that make me happy, even if it’s another ghost wall hanging,” she explains. “I want to add joy and beauty to the world, and I think that starts by making sure I like what I’m making.”

“I’m still the kid who drew doodles on everything,” she adds. “Crochet is just a new form of my artistic journey.” Perhaps seven-year-old Amber’s one-skein blanket wasn’t meant to be – but over the years, through play and purpose, she’s created a name for herself that is truly unmistakable.

Written by Tricia Fairburn

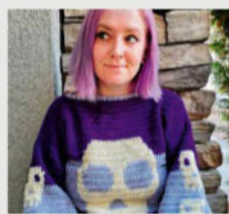

A few of her favourite things

When Amber’s not crocheting...

“I just adore relaxing before bed with a book and still weekly catch-up with my favorite comic books (fun fact, I have a Wonder Woman tattoo). And when we dare to venture out, my husband and I love to find and try craft beers.” Visit www.divinedebris.com or head to Instagram (@divinedebris) to find out more about Amber.

LOOKING FOR A GOOD YARN? VISIT YOUR WEBSITE.

ukhandknitting.com



FIND AN EVENT

Click on the calendar to discover local and national events

<	April 2024							>
	m	t	w	t	f	s	s	
1	2	3	4	5	6	7		
8	9	10	11	12	13	14		
15	16	17	18	19	20	21		
22	23	24	25	26	27	28		
29	30							

There are over 500 yarn shops in our community of independent retailers. Each one has a warm welcome and offers you the personal service you've always loved.

You can chat about a project. Feel the quality of the yarn. Pick up some useful advice. Join the shop's craft group. Invest in a stash for the future. And much, much more.

Before you start your next knitting or crochet project, or if you need help with an existing one, visit ukhandknitting.com to see what your yarn shops can offer you.

**WE ARE
UK HAND KNITTING**



Berries & cream

A wool blend beauty with pretty shells and a snuggly roll neck, designed by Cassie Ward

POLO NECK JUMPER



YOU WILL NEED

- DROPS Air
(65% alpaca, 28% polyamide,
7% wool, 50g/150m)
- Yarn A Wheat (02)
- Yarn B Ruby Red (07)
- Yarn C Heather (14)
- Yarn D Pink (24)
- Yarn E Aquamarine (27)
- See table for measurements
and yarn quantities

- A 4mm (US G/6) hook
- A 5mm (US H/8) hook
- Stitch markers

For yarn stockists contact

Wool Warehouse 01926 882818
www.woolwarehouse.co.uk

TENSION

2 pattern repeats and 8 rows
measure 9x9cm (3½x3½in) using a
5mm hook, or size needed to obtain
correct tension

ABBREVIATIONS

For a full list, see page 78

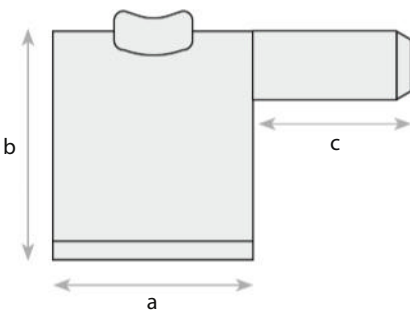

Width a: 50 (54.5: 59: 63.5: 68)cm,
19¾ (21½: 23¼: 25: 26¾)in
Length b: 59 (59: 59: 61.5: 61.5)cm,
23¼ (23¼: 23¼: 24¼: 24¼)in
Sleeve length c: 46cm, 18in

In these cold, dark months, embrace the cosy
vibes and hunker down in an oversized
jumper made in mouthwatering shades.

NOTES

The Shell Pattern is written out first and
referred back to in the pattern for the Jumper.
Jumper is made in separate parts for the
Front, Back and Sleeves. These are sewn
together. The Cowl is then worked around
the neck opening.
Change colour on the final yrh of row before
colour change is indicated. Work over yarn tails
where possible to reduce the number of ends
you need to weave in.

POLO NECK JUMPER

SHELL PATTERN

Row 1 (RS) Ch4 (counts as tr, ch1), tr in dc at
base of ch-4, ch2, *skip 4 tr, dc in fifth tr of 9-tr
group, ch2, skip 4 tr, (tr, ch1, tr) in next dc, ch2;
rep from * to final dc, (tr, ch1, tr) in dc, turn.

Row 2 (WS) Ch3 (counts as tr), 4tr in first ch-sp,
(dc in next dc, 9tr in next ch-1 sp) rep to last
ch-1 sp, 5tr in last ch-1 sp, turn.

Row 3 Ch1 (does not count as st throughout),
dc in first tr, skip 4 tr, *ch2, (tr, ch1, tr) in next dc,
ch2, skip 9 tr; rep from * to final st, dc in final st,
turn.

Row 4 Ch1, dc in first dc, (9tr in ch-1 sp, dc in
next dc) rep to end, turn.

JUMPER

BACK

RIB

Using a 4mm hook and Yarn A, ch11.

Row 1 Dc in second ch from hook, dc in each ch
to end, turn. [10 dc]

Row 2 Ch1, dc in bl of each st to end, turn.

Rep Row 2 another 87 (95: 103: 111: 119) times.
[89 (97: 105: 113: 121) rows worked in total]

MAIN BODY

Turn to work across row edge of Rib.



The shell pattern is worked over four rows
and is made up of groups of treble stitches

Row 1 (RS) Ch1, dc in each row-end across,
turn. [89 (97: 105: 113: 121) dc]

Change to a 5mm hook.

Row 2 (WS) Ch1, dc in first dc, (skip 3 dc, 9tr in
next dc, skip 3 dc, dc in next dc) rep to end, turn.
[11 (12: 13: 14: 15) shells, 12 (13: 14: 15: 16) dc]

Change to Yarn B.

Work in Shell Pattern until Jumper measures
approx 55 (55: 55: 58: 58)cm and using the
following colour sequence: 2 rows in Yarn B, 2
rows in Yarn C, 2 rows in Yarn D, 2 rows in Yarn
E, 8 rows in Yarn A. End on a Row 4 repeat of
Shell Pattern.

Fasten off all yarns except Yarn A.

SHOULDER SHAPING

Cont with Yarn A.

Row 42 Ch3, skip next st, *htr in next 2 sts, dc in

SIZE		S	M	L	XL	2X
TO FIT BUST	cm	81-86	91-97	102-107	112-117	122-127
	in	32-34	36-38	40-42	44-46	48-50
ACTUAL BUST (APPROX)	cm	100	109	118	127.5	136.5
	in	39¼	43	46½	50	53¾
LENGTH	cm	59	59	59	61.5	61.5
	in	23¼	23¼	23¼	24¼	24¼
SLEEVE LENGTH	cm	46	46	46	46	46
	in	18	18	18	18	18
YARN A	50g	6	7	7	8	8
YARNS B-E	50g	2	2	3	3	4

To make this pattern easier to follow, we've colour-coded the sizing instructions – simply follow the relevant column.

POLO NECK JUMPER

next 3 sts, htr in next 2 sts, tr3tog; rep from * to last 9 sts, htr in next 2 sts, dc in next 3 sts, htr in next 2 sts, tr2tog, turn.

[89 (97: 105: 113: 121) sts]**

Row 43 Ch3, tr in each st to end, turn.

Row 44 Ch3, 27 (30: 34: 36: 40)tr, turn leaving rem sts unworked. [28 (31: 35: 37: 41) tr]

Row 45 Ch3, tr in each st across, turn.

Fasten off.

Skip centre 33 (35: 35: 39: 39) sts, join Yarn A in next st.

Work Rows 44-45 on opposite side.

Fasten off.

FRONT

Work as for Back to **.

SHAPE NECK

Row 43 Ch3, 27 (30: 34: 36: 40) tr, turn leaving rem sts unworked. [28 (31: 35: 37: 41) tr]

Rows 44-45 Ch3, tr in each st to end, turn.

Fasten off.

Skip centre 33 (35: 35: 39: 39) sts, join Yarn A in next st.

Work Rows 43-45 on opposite side.

Fasten off.

SLEEVES (MAKE 2)

CUFF

Using a 4mm hook and Yarn A, ch11.

Row 1 Dc in second ch from hook, dc in each ch to end, turn. [10 dc]

Row 2 Ch1, dc in bl of each st to end, turn.

Rep Row 2 another 30 (30: 34: 38: 42) times.

[32 (32: 36: 40: 44) rows worked in total.

Do not fasten off.

MAIN SLEEVE

Cont with Yarn A.

Row 1 (RS) Ch1, 3dc in first row-end, 2dc in each row-end across, turn. [65 (65: 73: 81: 89) dc]

Change to a 5mm hook.

Row 2 Ch1, dc in first dc, (skip 3 dc, 9tr in next dc, skip 3 dc, dc in next dc) rep to end, turn.

[8 (8: 9: 10: 11) shells, 9 (9: 10: 11: 12) dc]

Work in Shell Pattern for 32 rows, using colour sequence as for Back/Front.

Cont with Yarn A.

Row 34 Ch3, skip next st, *htr in next 2 sts, dc in next 3 sts, htr in next 2 sts, tr3tog; rep from * to last 9 sts, htr in next 2 sts, dc in next 3 sts, htr in next 2 sts, tr2tog.

Fasten off.

TO MAKE UP

Work all joining with a whipstitch and WS facing.

Sew Front to Back together at shoulder seams. Fold Sleeve in half and pin the centre-top to the shoulder seam, pin the top edge of the Sleeve to the Front and Back. Once happy with the position, sew in place.

Sew side and Sleeve seams closed.

COWL NECK

Using a 4mm hook, join Yarn A at left shoulder seam to work around neck opening.

Round 1 (RS) Ch1, dc around neck opening working 1dc in each st and 2dc in each tr row-end (making sure you work an even number of sts), ss to beg dc.

Round 2 (RS) Ch3 (counts as first tr), tr in each st around, ss to top of beg ch-3.

Round 3 Ch3, (FPtr around next st, BPtr around next st) rep around to end, ss to top of beg ch-3.

Rep Round 3 another 17 (17: 19: 19: 21) times.

Fasten off and weave in all ends.



In the colour sections, change yarn shade every two rows to create stripes of shells

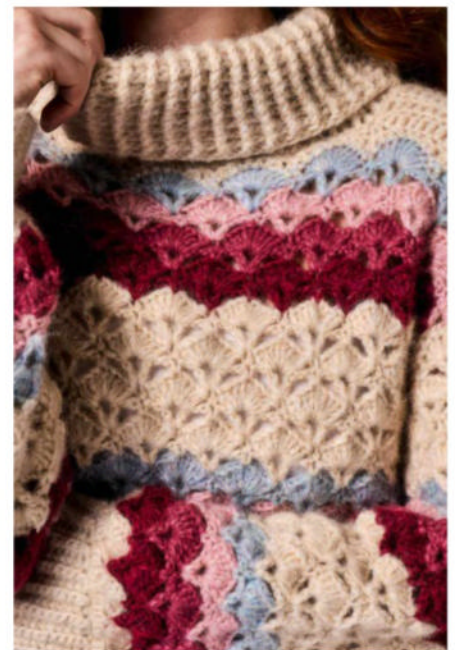

To create the deep, ribbed cowl, work treble stitches around front and back posts

SIMPLE STEPS HOW TO WASH YOUR CROCHET PIECES



1 Keep the yarn's ball band safe and check it for care information. The band will tell you what temperature to wash the yarn at and whether it can go in the machine or if it needs to be handwashed.



2 To handwash, soak for around 30 minutes in a bowl of lukewarm water with a mild detergent. Don't rub or you may felt the piece. Then rinse, unless you've used a non-rinsing detergent, such as Soak or Eucalan.



3 Lay the crochet item on top of a towel and roll up the towel to squeeze out excess moisture, making sure you do not wring.



4 Gently reshape the crochet item. Leave it to dry on a towel somewhere flat, such as on a board or a folded blanket. Pin out if needed. Never hang up an item to dry because its weight may stretch the yarn.

Colour pop

Gemma William's stylish rug is a simple way to switch up your décor this new year

BUST YOUR STASH





YOU WILL NEED

- Scheepjes Softfun (60% cotton, 40% acrylic, 50g/140m)
1 ball of each: Dove (2510), Bright Turquoise (2423), Latte (2622), Violet (2519), Pumpkin (2651), Hot Pink (2495), Light Rose (2513), Bumblebee (2634)
- A 4mm (US G/6) hook
- A tapestry needle

For yarn stockists contact
Scheepjes
www.scheepjes.com/en

TENSION

20 sts and 12 rows measures
10x10cm (4x4in) over pattern using
a 4mm hook, or size needed to
obtain correct tension

MEASUREMENTS

Rug measures approx 30x100cm
(12x39in)

ABBREVIATIONS

Fhtr (Foundation half treble) Ch3 (counts as first st), insert hook in last ch from hook, yrh and pull up a loop, pull through one loop on hook (loop will sit at base of Fhtr), yrh and pull through 3 loops on hook *insert hook in loop at base of prev Fhtr, yrh and pull up a loop, yrh and pull through one loop on hook (loop will sit at base of Fhtr), yrh and pull through 3 loops on hook; rep from * as required

htr3L (htr in third loop) Yrh, insert hook into third loop of next st, yrh and pull up a loop, yrh and pull through all loops on hook

For a full list, see page 78

Don't worry about following a pattern with this rug – embrace random colour changes to create a unique item for your home.

NOTES

This pattern is designed as a stash buster. You can use any DK weight yarn and change colour as frequently and randomly as you desire.

You can make your rug any width by adjusting the starting Fhtr and any length by adding or removing rows.

STRIPED RUG

Row 1 (WS) Using Dove, Fhtr 60, turn. [60 sts]
Change colour randomly throughout.

Row 2 (RS) Ch1 (does not count as st throughout), htr3L in each st to end, turn.

Rows 3-120 Rep Row 2.

Fasten off and weave in ends.

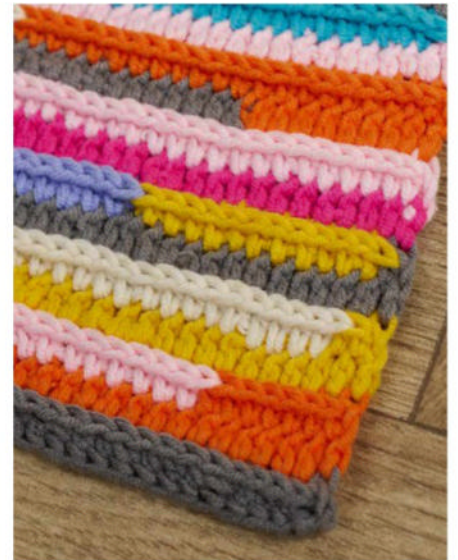

The rug is made entirely of half treble stitches worked into the third loop of the next stitch

Choose your own yarn shades and change them as often as you like!

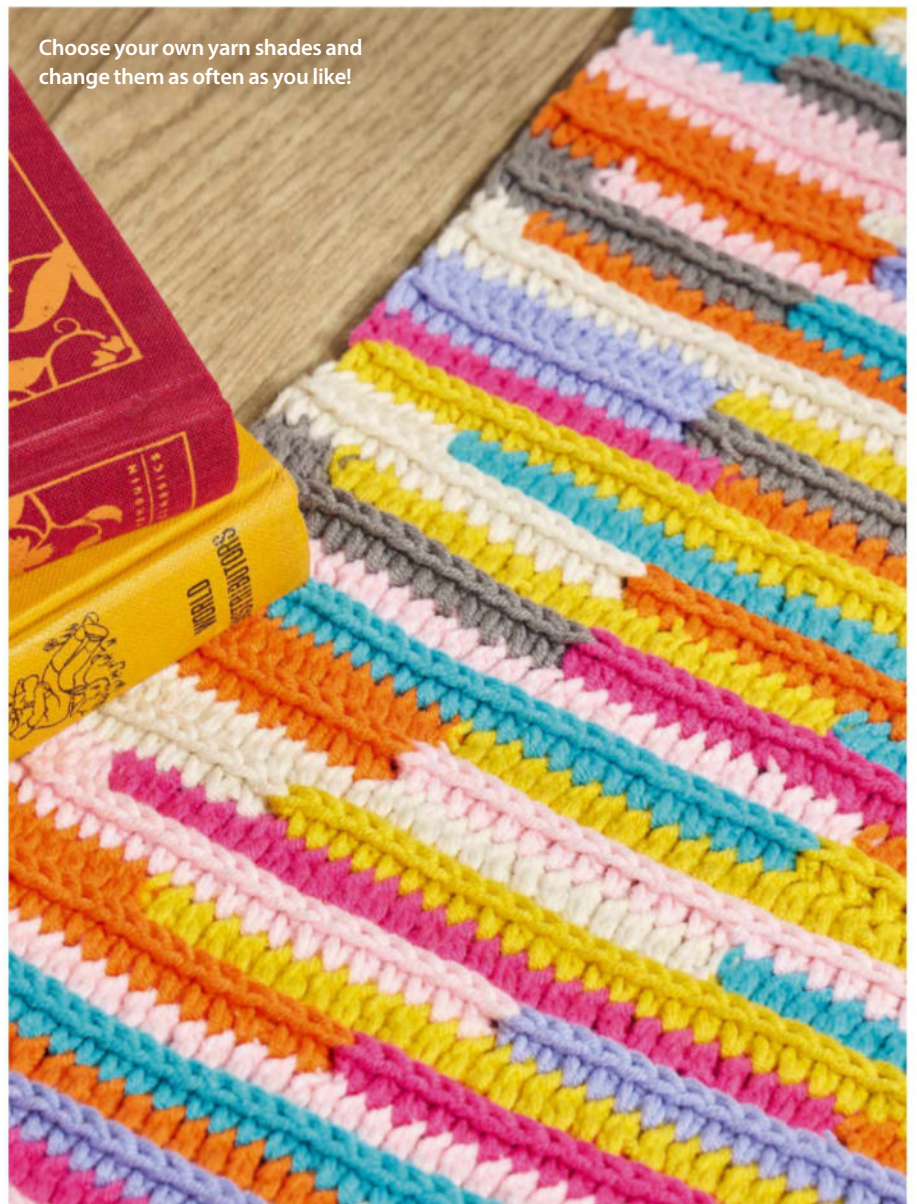

NEW!

gathered.shop

Discover your next creative project

Discover 100s of patterns from the UK's best-loved craft magazines to download instantly

SPECIAL OFFER
SAVE 15% OFF YOUR FIRST PURCHASE

USE CODE
SC17015

From cosy knits to creative embroidery, beautiful quilting to modern sewing – we've handpicked the best designs from brands you trust. Simply download and get making.

- ✓ Exclusive designs
- ✓ Tested by our experts
- ✓ Download straight away and start crafting

Get 15% off your first purchase – just visit gatheredshop.com and start crafting today!

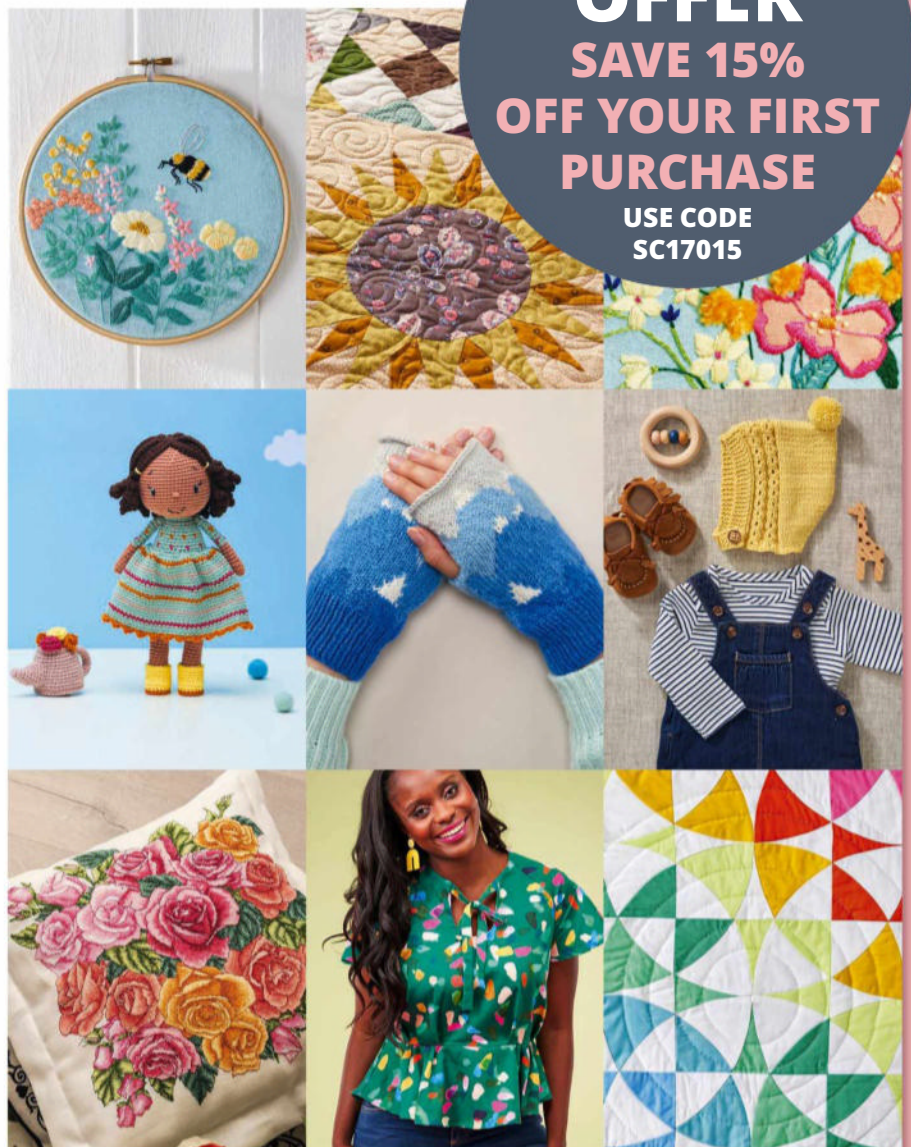
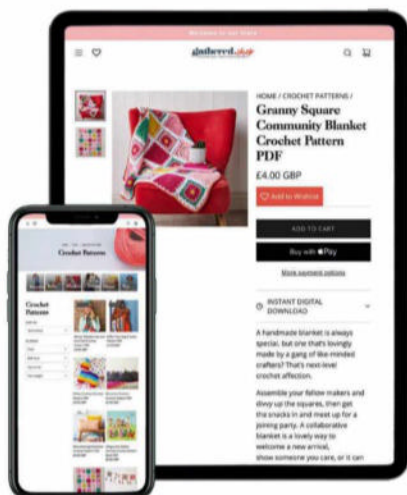

Offer valid for 15% off selected collections at Gathered Shop (www.gatheredshop.com). To redeem enter the offer code at checkout. No minimum purchase required. Available to all customers, one use per customer. Cannot be combined with other discounts or promotional offers. Gift cards excluded. Offer valid until 17th March 2026, 11:59 PM.

Shop now & save 15% at gatheredshop.com



YOU WILL NEED

- Oddments of any sock yarn
- A 3.5mm (US E/4) hook
- 2 buttons, 15mm
- Clear glass seed/rocaïlle beads, size 6 (available from: <https://bit.ly/49O8Mvr>)
- A beading needle
- Stitch markers

TENSION

Tension is not critical, but it may affect the yarn quantities required

MEASUREMENTS

Bracelet measures approx 18cm (7in) in circumference when fastened

ABBREVIATIONS

bch Slide a bead up to your hook, yrh with yarn below the bead, pull though loop on hook
 For a full list, see page 78

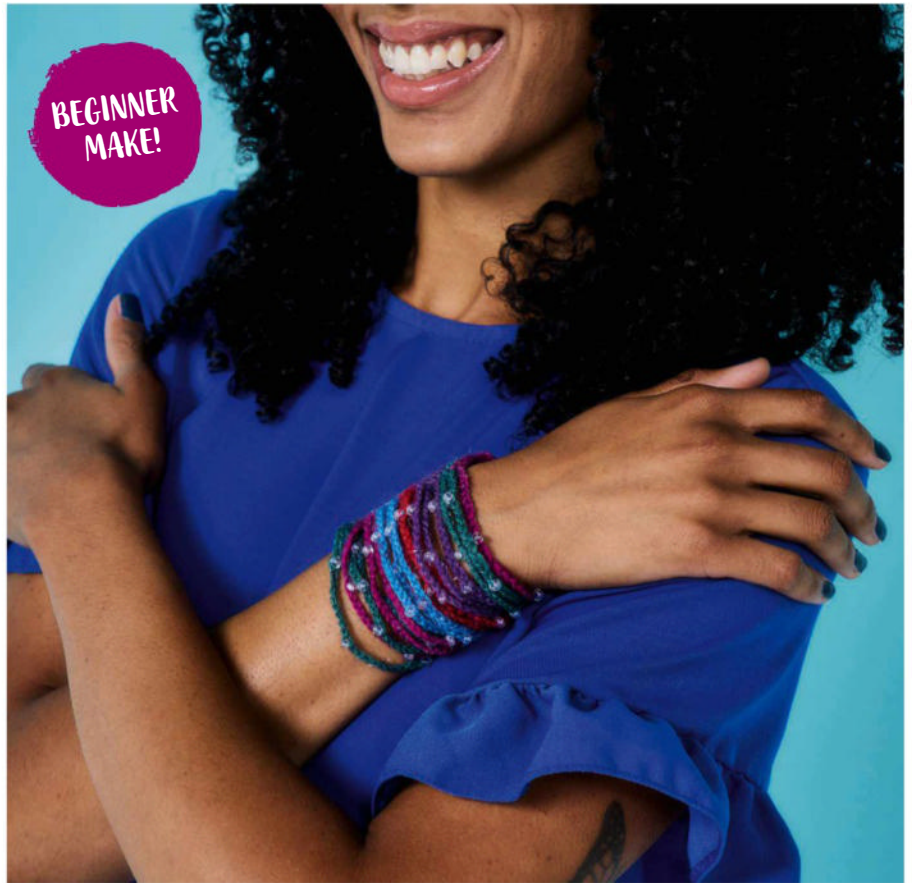

Magic circle

Hold on to your scraps! Claire Fearnley's striped bracelet is a clever use of yarn, beads and buttons



When crocheting with beads, thread the beads onto the yarn before starting to hook

This cute cuff has the look of small, individual bracelets, but they're all connected – so you never have to worry about losing them.

NOTES

Bracelet is worked in rows.
 Stitch markers will help to stop the Bracelet from getting twisted as you work.
 Buttonholes are worked along one short edge of the Bracelet with the buttons sewn to the opposite edge.

BEADED BRACELET

Using the beading needle, thread 54 beads onto the yarn.
Foundation row Ch7, pm in last ch, ch4, bch, ch9, bch, ch9, bch, ch17, turn.
Row 1 (RS) Dc in second ch from hook, dc in next 6 ch, ch4, bch, ch9, bch, ch9, bch, ch9, dc in marked ch, dc in next 6 ch, turn.

[14 dc, 3 bch, 3 ch-9 sps, 1 ch-4 sp]
Row 2 (WS) Ch1 (does not count as st throughout), 7dc, ch4, bch, ch9, bch, ch9, bch, ch9, dc in final 7 dc, turn.
Rows 3-18 As Row 2.
 Do not turn at end of Row 18.

BUTTONHOLES

Work next row across row-end edge.
Row 1 (WS) Ch1, dc in first 4 row-ends, (ch3, skip 3 rows, dc in next 4 row-ends) twice, turn. [12 dc, 2 ch-3 sps]
Row 2 (RS) Ch1, 4dc, (4dc in ch-3 sp, 4dc) twice. [20 sts]
Fasten off.

TO FINISH

Sew the buttons to the opposite edge of the Bracelet, in line with the buttonholes.

Little darling

Treat a baby, toddler or young child to a fun cardigan by Simone Francis

WORKED IN
ONE PIECE



BABY CARDIGAN



YOU WILL NEED

- DROPS Nepal
(65% wool, 35% alpaca 50g/75m),
Yarn A Light Beige Mix (0206)
Yarn B Raspberry Rose (8910)
See table for measurements and
yarn quantities of Yarns A and B
1 ball of each:
 - Yarn C** Sage Green (8923)
 - Yarn D** Forget-Me-Not (8783)
 - Yarn E** Goldenrod (2923)
 - Yarn F** Royal Blue (6790)
 - A 5mm (US H/8) hook
 - A 6mm (US J/10) hook
 - Ribbon, 75cm
- For yarn stockists contact**
Wool Warehouse 01926 882818
www.woolwarehouse.co.uk

TENSION

11.5 sts and 7 rows to measure
10x10cm (4x4in) over treble crochet
using a 6mm hook

ABBREVIATIONS

For a full list, see page 78

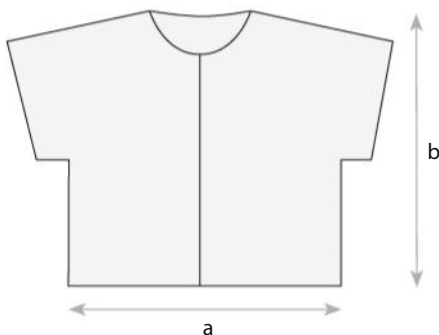

Width a: 29.5 (31.5: 33: 35)cm
11½ (12½: 13: 13¾)in
Length b: 33 (36: 39: 41)cm
13 (14: 15¼: 16)in

We love making baby clothes – they're cute, they're quick, and they double up as both stash busters and thoughtful gifts!

NOTES

Cardigan is worked from top down, in one piece. Keep checking the placement of stitches and stitch counts at the end of each row of the Yoke to ensure correct results.

Some of the yarn shades used in the sample have been discontinued but close matches have been listed.

CARDIGAN

YOKE

Using a 6mm hook and Yarn A, ch36 (41: 41: 41).

Foundation row Dc in bl of the second ch from the hook and in each ch to end, turn.

[35 (40: 40: 40) sts]

Row 1 (WS) Ch1 (does not count as st throughout), *4dc, 2dc into the next st; rep from * to last 5 sts, dc to end, turn.

[41 (47: 47: 47) sts]

Change to Yarn B.

Row 2 (RS) Ch1, 2htr, 2htr into the next st, *3 (5:

5: 5) htr, 2htr into the next st; rep from * to the

last 2 sts, htr to end, turn. [51 (55: 55: 55) sts]

Change to Yarn C.

Row 3 Ch1, dc into the first st, skip 2 sts, (2tr, ch1, 2tr) into the next st, *skip 1 st, dc into the next st, skip 1 st, (2tr, ch1, 2tr) into the next st; rep from * to the last 3 sts, skip 2 sts, dc into the last st, turn. [12 (13: 13: 13) patt reps]

Change to Yarn D.

Row 4 Ch3 (counts as tr throughout), tr in st at base of ch-3, *skip 2 tr, 4htr into the ch-1 sp, 2tr into the next dc; rep from * to end, turn.

[25 (27: 27: 27) clusters]

Change to Yarn E.

Row 5 Ch2 (counts as htr), htr in st at base of ch-2, skip 1 tr, *(ch1, 3htr) into the sp between groups; rep from * to the last 2 sts, ch1, 2htr in last st, turn. [26 (28: 28: 28) clusters]

Change to Yarn F.

Row 6 Ch1, dc in first st, 4tr into each ch-1 sp to end, dc in last st, turn.



The cute cardi has a seamless construction, meaning there's no sewing up to do

[102 (110: 110: 110) sts]

Change to Yarn C.

Row 7 Ch1, dc into each st to end, turn. Change to Yarn B.

Row 8 Ch1, dc in bl of each st to end, turn.

Change to Yarn A.

FOR SIZES 1-2, 3-4 AND 5-6 ONLY

Row 9 Ch3, tr into each st to end, turn.

FOR SIZE 7-8 ONLY

Row 9 Ch3, 4tr, 2tr into the next st, *19tr, 2tr into the next st; rep from * to last 5 sts, tr to end, turn. [116 sts]

ALL SIZES

Row 10 Ch3, tr into each st to end, turn.

[102 (110: 110: 116) sts]

Repeat Row 10 another 0 (1: 2: 3) times.

Do not fasten off.

DIVIDE FOR FRONT/BACK/SLEEVES

Foundation row Ch3, 14 (15: 15: 16)tr, ch4 (4: 6: 6), skip 21 (23: 23: 24) sts, 30 (32: 32: 34)tr, skip 21 (23: 23: 24) sts, ch4 (4: 6: 6), 15 (16: 16: 17)tr, turn. [68 (72: 76: 80) sts]

Row 1 Ch3, tr into each st to end, turn.

Repeat Row 1 another 6 (7: 8: 9) times, changing

SIZE		1-2 years	3-4 years	5-6 years	7-8 years
TO FIT CHEST	cm	53	56	61	66
	in	20¾	22	24	26
ACTUAL CHEST (APPROX)	cm	59	63	66	70
	in	23¼	24¾	26	27½
LENGTH	cm	33	36	39	41
	in	13	14	15¼	16
YARN A	50g	2	3	3	3
YARN B	50g	1	2	3	3

To make this pattern easier to follow, we've colour-coded the sizing instructions – simply follow the relevant column.

to Yarn B.
Rep Row 1 another 3 times.
Fasten off.

SLEEVES (MAKE 2)

With WS (RS: WS: RS) facing and using a 6mm hook, join Yarn B to 3rd (3rd: 4th: 4th) underarm ch.

Foundation round Ch3, tr into next 1 (1: 2: 2) ch, 2tr into corner st of Body before skipped sts, 21 (23: 23: 24) tr into the skipped sts, 2tr into corner st of Body before underarm chain, tr into the next 2 (2: 3: 3) ch, ss to the top of the beginning ch-3, turn. [29 (31: 33: 34) sts]
Change to a 5mm hook.

Round 1 Ch3, tr into each st around, ss to the top of the beginning ch-3.
Cont with RS facing.

Round 2 (RS) Ch1, dc in each st around, ss to beg dc.

Fasten off.

EDGINGS

With RS facing and using a 6mm hook, join Yarn B at top of Yarn B rows at the bottom of the left front.

Ss evenly along the front edge row-end in Yarn B to bottom, ch1, dc in each st along bottom edge, ss up front edge of Cardigan over Yarn B rows.

Change to Yarn A.

Ss evenly around front edges and neck to first ss in Yarn B.

Fasten off.

TO FINISH

Weave in all ends and gently steam block work. Cut ribbon in half and sew neatly to Cardigan, using the image as a guide.



A matching ribbon bow is the perfect final touch



The yoke is worked in bright stripes of textured stitches for a vibrant look



Sleeves and hem are finished with a bold border of treble stitches in contrasting colour

SIMPLE STEPS HOW TO CHANGE COLOUR IN ROWS



1 Start working the last stitch of the last row of the old colour, but stop before you work the final yrh of the stitch. Cut off the old yarn, leaving a tail about 7cm long.



2 Now loop the new yarn colour around the hook, leaving a long tail of yarn (about 7cm long).



3 Pull the new yarn loop through the remaining 2 loops to finish off the stitch. Pull the old and new yarn ends to tighten the loop on the hook.



4 Now you can work the turning chain of the new row in the new colour (eg, 3ch for treble). Then work the stitches of the new row in the new yarn colour.



Luxury Travel
since 1927



Luxury river and yacht journeys with everything taken care of

For over 95 years, APT has specialised in seamless, high-touch travel. Their luxury collection spans Europe's great rivers and intimate yacht sailings, pairing elegant ships with curated sightseeing and generous inclusions. Return UK flights, attentive Cruise Directors, quality drinks with meals and considerate touches throughout mean you can relax and enjoy the view while APT looks after the rest.



Join Cruise Collective for free
and unlock exclusive savings

SAVE UP TO £200 PP
CALL 0800 0463 006 AND
QUOTE **CC2026 TO BOOK**



cruise-collective.com

Terms & Conditions apply



Dr Anne Kirketerp, Danish craft teacher turned psychologist, explains the science behind craft and wellbeing in her book



PHOTO: Dr Anne Kirketerp

Matters of the mind

Psychologist Dr Anne Kirketerp's book explains the science behind why we love crafting – and explains why we should have up to 30 projects on the go!



PHOTO (top right): Dr Anne Kirketerp



Clockwise from left: different moods call for different projects; Anne enjoying a craft project over a cuppa; the 'micro movements' of crochet prove beneficial to health

While we're used to news about scientific breakthroughs, we don't often hear of the spread of scientific knowledge coming about through sheer chance. But this is exactly what happened when Peter Hobolt Jensen, Chief Marketing Officer of crafting business DMC Group, found Dr Anne Kirketerp. He had been searching worldwide for researchers to work with on promoting the health benefits of craft, when he was surprised to find that close to home in Denmark, Anne had already written a book on the subject: *Craft Psychology: How Crafting Promotes Health*. In turn, Anne was keen to get her book translated and distributed abroad, so she was delighted when Peter contacted her and they were able to work together.

A NEW SCIENTIFIC FIELD

While most of us would agree that everyone could benefit from taking part in a craft of some kind, we may not know exactly why, what the effects of crafting are and how we can deliberately enhance them. Anne's book explains all this, demonstrating the science behind the benefits.

Anne is the first person to establish craft psychology as a scientific field in itself, but when she started her research, although 470

papers had been published on aspects of the topic, no one had "described or investigated the overarching psychological effects of crafting, such as relaxation, mental development, and mental restoration."

As well as being an academic, Anne is a professional crafter, and has always been fascinated by why we craft. She spent four years analysing the papers, researching and collecting hundreds of answers to the question "why do I craft?" Finally, she was able to confirm that the phenomenon of craft psychology can be scientifically proven to help everyone's lives.

MICRO MOVES AND SUCCESSES

Anne used the work of Betsan Corkhill, previously seen in *Simply Crochet* talking about her research into how yarn crafts can help with pain management, and that of others to show that "unpaid hobby activity creates the opportunity for a flow state where you feel completely immersed and forget yourself."

You've likely experienced this 'flow state': you're so engrossed in your craft, time flies and you're left wondering where the last hour went. "By working with our hands, we become fully present and immersed in an activity that allows us to forget our troubles and be in the moment," explains Anne.

Although Anne is a multi-crafter, she loves crochet because the hand movements are intricate and refined, as well being the perfect technique for making heirloom blankets that never go out of style! "There are more micro movements in crochet than in knitting; knitting becomes 'automatic' very quickly," she states. "Crochet demands grounding here and now: you have to be focused on where you're putting your hook into each stitch, which demands more cognitive ability than a knitting stitch." It's also easier for beginners because you're only dealing with one stitch at a time, which is difficult to drop. "It's a huge relief for many that it won't all unravel if you undo three stitches, and it's easy to make tiny projects that give a very fast 'micro success' experience."

EASING THE STRESS

The repetitive movements of craft activities have been shown to induce a relaxation response, which is the body's way of tackling stress. Heart rate, stress hormones and blood pressure all drop, and breathing calms. Focus shifts to what you're making and moves away from negative thoughts.

This effect is especially helpful to those with a wide range of conditions, such as anxiety, depression, compulsive behaviours, ADHD and substance abuse. People with

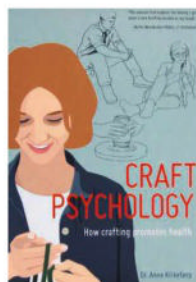

PHOTOS: Dr Anne Kirketerp

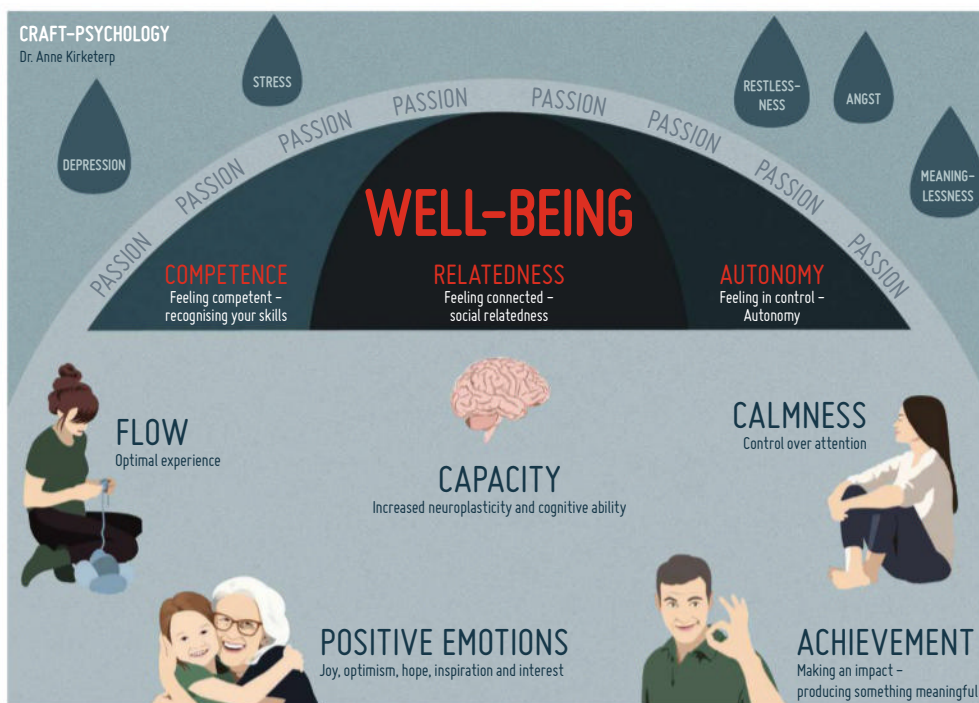

Anne's research scientifically proves the health benefits of crafting, from alleviating anxiety to reducing the risk of dementia

these conditions can feel that they don't have much control over their lives but, as Anne says, "craft helps you focus on processes that you have control over."

An example of this is Anne's work with a hospital, teaching crochet to patients with eating disorders. "Having to count takes all your attention and moves the focus from symptoms such as wanting to over-exercise," she explains. "It's also easy to pick up and put down for short periods of time." The series of small successes, seen with each completed stitch, improves self-esteem and strengthens the belief that activities in other areas of life can also succeed.

While health professionals also prescribe sport for stress, Anne explains that craft can be easier to maintain. "People often stop exercising when they're not being 'made' to do it, whereas with craft, they are much more likely to continue because suddenly they are 'allowed' to engage in or find their passion to lower stress responses."

Social anxiety, which makes it tough to go out and meet others, can be countered with 'coupled activities' such as crafting in a social setting. If 50% of people's attention is on the craft, there's always something else to do,

talk about and learn, rather than worrying how you are being perceived or if you've said the right thing. Learning new things also helps stave off dementia, keeping the brain active and creating new synapses due to the use of fine motor skills, while crafting for charity gives an added sense of purpose.

Anne runs courses for teachers from early years to university level, and is working with Denmark's Ministry of Education to integrate craft psychology institutionally. The idea is that practical education and crafts should be treated the same as theoretical subjects, and to embed this view at all stages in education, as well as in health and occupational therapy.

SAY NO TO GUILT, YES TO PROJECTS!

We're culturally hardwired to believe that we should finish what we start, and shamed for having multiple, unfinished projects. But at a recent Rowan wellness retreat weekend, Anne explained that her research shows this approach is bad for our health. Instead, we need *lots* of projects to choose from, and what we choose depends on our mental state. When you're tired or stressed, work on an easy, calming project. When you have more energy, learn a new skill or plan a

design to keep you fully engaged – it's impossible to feel anxious while creating something that takes all your attention. The retreat attendees were delighted to get permission from a Doctor of Psychology that we need at least 10 to 30 different projects! Anne herself has eight big boxes full: some items for "the worn-out Friday" and others for "the well-rested Saturday".

Anne adds we shouldn't be embarrassed not to finish projects we're finding boring. "If you're feeling 'I should', and putting pressure on yourself, then no, you shouldn't! Go back to it another time. Don't pollute your passion and intrinsic motivation by overstepping your energy levels, or getting to the point where your hobby feels the same as cleaning the house. While it's good to finish some items, if craft becomes compulsory, it no longer works as promoting wellbeing."

Anne is keen to set crafters free from guilt and to encourage us to see the task and process as its own reward. So go ahead, start that new project and improve your health!

Written by Debora Bradley
Craft Psychology by Dr Anne Kirketerp is available from www.knitrowan.com for £14.95. Find out more at www.craftpsychologi.dk

YOUR EXTRA GIFT

SIGN UP TODAY!



BONUS DIGITAL GIFT

Download your free copy of Amigurumi Collection

► Sign up for our monthly newsletter and you'll receive the link to download our Amigurumi Collection for free. This one's full of animal toys, from a teddy in beach shorts to a sleepy sloth. You can also stitch a pencil topper, tiny campervan and smiley ice cream. There are 47 patterns in total, and the bookazine is worth £8.99 – but you'll get it for free! Just head to our website: www.gathered.how/newsletters





Premium river and Croatia yacht adventures with generous inclusions

Travelmarvel, part of the award-winning APT Travel Group, holds an Excellent rating on Trustpilot and delivers great value with well-run itineraries across Europe, Egypt and Asia, plus intimate yacht cruising on the Croatian coast. Return UK flights, overseas transfers, meals with beer, wine and soft drinks, curated excursions and tipping are all taken care of, so you can focus on the view.

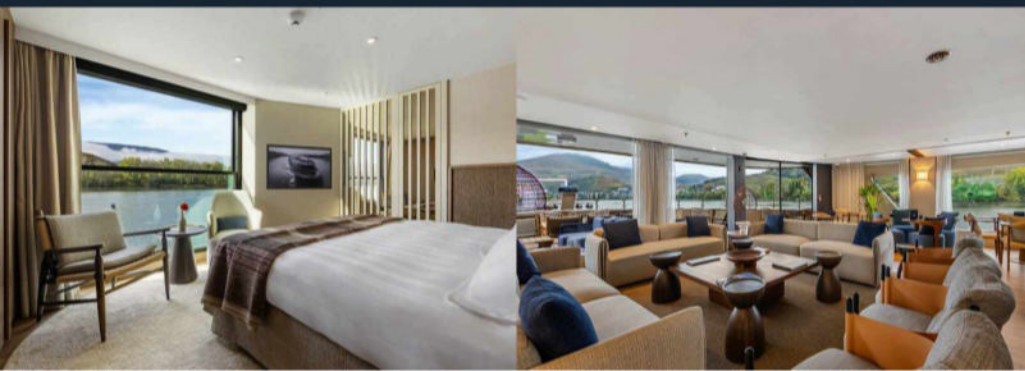

Join Cruise Collective for free and unlock exclusive savings

SAVE UP TO £150 PP
CALL 0800 0463 006 AND
QUOTE CC2026 TO BOOK



cruise-collective.com

Terms & Conditions apply

Kindred spirits

Catherine Venner's twin cushions bring homely vibes to cosy corners

STYLE YOUR HOME!



PAIR OF CUSHIONS



YOU WILL NEED

- Caron Simply Soft (100% acrylic, 170g/288m)
To make both cushions:
3 balls Feathered Gray (9794)
1 ball of each:
Plum Perfect (9761)
Dark Sage (9707)

- A 5mm (US H/8) hook
 - 2 cushion pads, 42x42cm
- For yarn stockists contact**
Readicut www.readicut.co.uk

TENSION

13 sts and 15 rows to measure 10x10cm (4x4in) over main pattern using a 5mm hook, or size needed to obtain correct tension

MEASUREMENTS

To fit cushion pad measuring 42x42cm (16½x16½in)

ABBREVIATIONS

For a full list, see page 78

These cushions can be paired in whatever colour combo you wish – why not personalise them and give as housewarming gifts?

NOTES

Cushions are made of a Front and Back panel, which are worked in rows and sewn together. Cushions are worked in 2 colourways. Colourway 1 is written first with colourway 2 in brackets. Feathered Gray is used as the primary colour in both colourways. To make a single Cushion, you will need 2 balls of Feathered Gray and 1 ball of a second colour.

CUSHIONS

FRONT

Using Feathered Gray and ch53.

Row 1 (RS) Dc into second ch from hook, dc in each ch across, turn. [52 sts]

Row 2 (WS) Ch1 (does not count as st throughout, dc in each st across, turn.

Row 3 Ch1, 4dc, (4FPtr over sts 2 rows below, skip 4 sts in current row, 4dc) 6 times, turn.

Row 4 Ch1, dc in each st across, turn.

Row 5 Ch1, 4dc, (4FPtr around FP sts 2 rows below, skip 4 sts in current row, 4dc) 6 times, turn.

Row 6 Ch1, 5dc, *change to Plum Perfect (Dark Sage), 2dc, change to Feathered Gray, 6dc; rep from * 5 times more, omitting final dc on last rep, turn.

Row 7 Ch1, 3dc, *2FPtr around first 2 FPtr 2 rows below, skip 2 sts on current row, change to Plum Perfect (Dark Sage), 2dc, change to Feathered Gray, 2FPtr over last 2 FPtr 2 rows below, skip 2 sts on current row, 2dc; rep from * 5 times more, 1dc, turn.

Row 8 Ch1, 4dc, *change to Plum Perfect (Dark Sage), 4dc, change to Feathered Gray 4dc; rep from * 5 times more, turn.

Row 9 Ch1, 2dc, *2FPtr around first 2 FPtr 2 rows below, skip 2 sts on current row, change to Plum Perfect (Dark Sage), 4dc, change to Feathered Gray, 2FPtr around next 2 FPtr 2 rows below, skip 2 sts on current row; rep from * 5 times more, 2dc, turn.

Rows 10-11 Rep Rows 8-9.

Row 12 Rep Row 8.

Row 13 Ch1, 3dc, *2FPtr over first 2 FPtr 2 rows below, skip 2 sts on current row, change to Plum Perfect (Dark Sage), 2dc, change to Feathered Gray, 2FPtr over next 2 FPtr 2 rows below, skip 2 sts on current row, 2dc; rep from * 5 times more, 1dc, turn.

Row 14 Ch1, 5dc, *change to Plum Perfect (Dark Sage), 2dc, change to Feathered Gray, 6dc; rep from * 4 times more, change to Plum Perfect (Dark Sage), 2dc, change to Feathered Gray, 5dc, turn.

Fasten off Plum Perfect (Dark Sage).

Row 15 Ch1, 4dc, (4FPtr around FP sts 2 rows below, skip 4 sts on current row, 4dc) 6 times, turn.

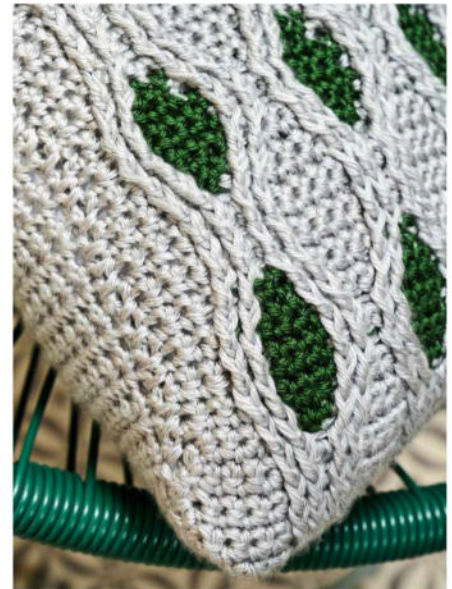

Keep tension strong throughout as the fabric will be under pressure from the cushion pad



For the textured lines, work trebles around front post stitches two rows below

Row 16 Ch1, dc in each st across, turn.

Rows 17-18 As Rows 15-16.

Repeat Rows 6-18 another 3 times.

Rows 58-59 As Rows 15-16.

Fasten off.

BACK

Using Feathered Gray and ch53.

Row 1 Dc into second ch from hook, dc in each ch across, turn. [52 sts]

Row 2 Ch1, dc in each st across, turn.

Rep Row 2 until Back measures 40cm.

Fasten off.

TO MAKE UP

Using Feathered Gray, sew Front and Back together, enclosing the cushion pad as you join. Weave in all ends.



For a more luxurious make, try West Yorkshire Spinners Fable Brushed Aran: 6 balls of Siren (1227), 2 balls of each: Rubus (1266), Moss (1230). Check hook size, tension and ball length if you use a different yarn.

For yarn stockists contact
www.wyspinners.com

Cut out
and keep



FILET WINDOWS

A combination of chains and trebles creates these gorgeous little squares – just the ticket for dainty makes

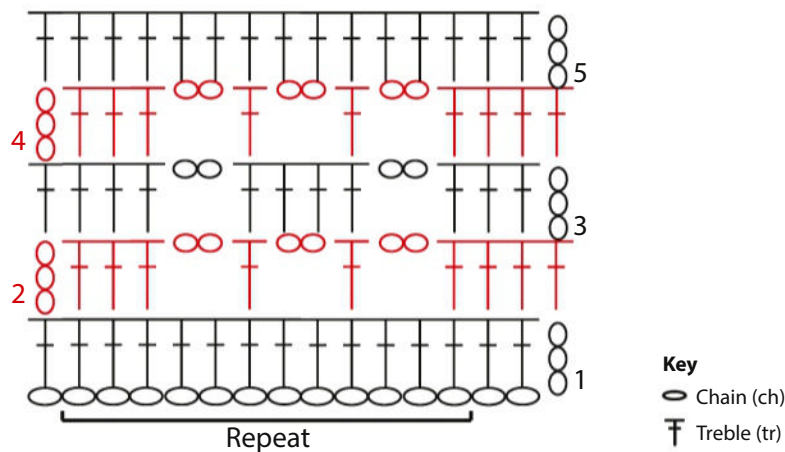
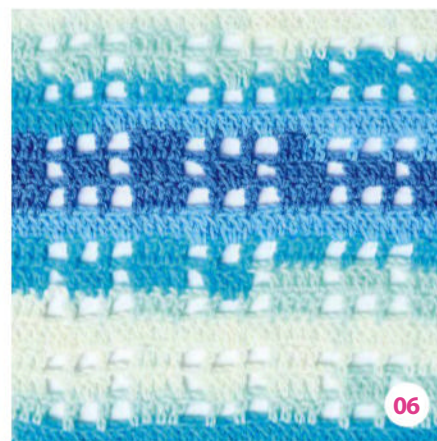
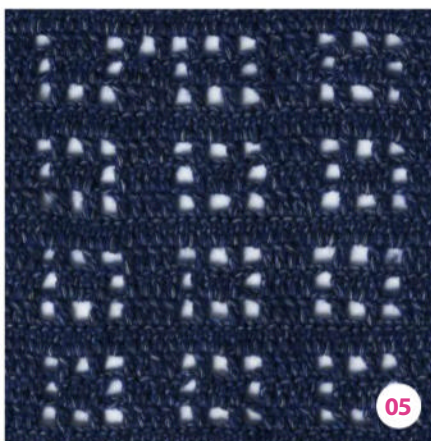
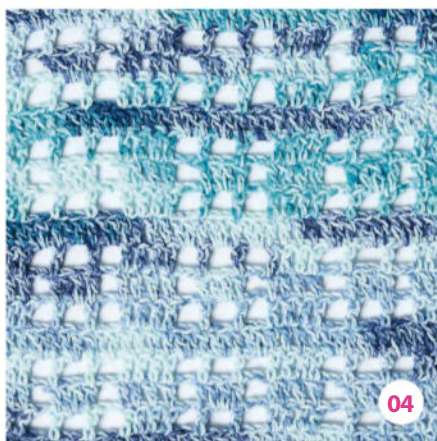
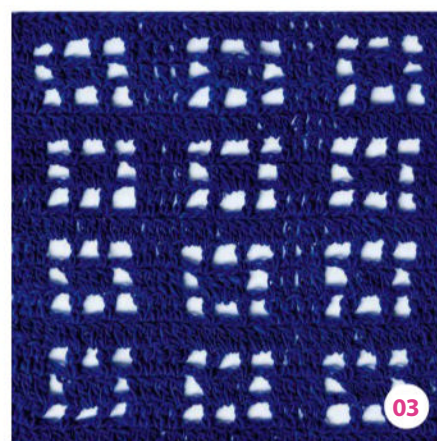
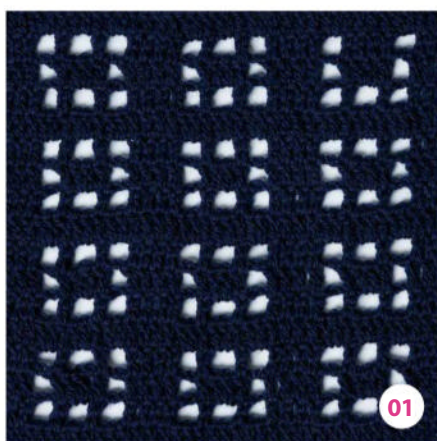

FILET WINDOWS

Ch a multiple of 12 plus 6.

Row 1 Tr in fourth ch from hook, tr in each ch across, turn.

Row 2 Ch3 (counts as tr throughout), tr in next 3 sts, *(ch2, skip 2 sts, tr in next st) 3 times, tr in next 3 sts; rep from * across to end, turn.

Row 3 Ch3, tr in next 3 sts, *ch2, skip 2 sts, tr in next st, 2tr in ch-sp, tr in next st, ch2, skip 2 sts, tr in next 4 sts; repeat from * to end, turn.

Row 4 As Row 2.

Row 5 Ch3, tr in each st across, turn.

Rows 2-5 set pattern.

WEST YORKSHIRE SPINNERS
MORRIS

WEIGHT DK
BALL 50g/112m
PRODUCT 100% wool
HOOK 4mm
RRP £6.50

This robust yarn offers fantastic stitch definition, making it a go-to choice for colourwork and Fair Isle crochet projects. A collaboration between West Yorkshire Spinners and the William Morris Society, it reflects the heritage and creativity of both brands, with a variety of



01

opulent colours. Made in Yorkshire from 50% Bluefaced Leicester, 25% Masham and 25% Bluefaced Leicester Kerry Hill, it blends softness and sheen with strength, durability and bounce – ideal for classic makes with a traditional vibe.

www.wyspinners.com

NORO
SONATA

WEIGHT 4ply
BALL 100g/360m
PRODUCT 35% cotton, 25% viscose, 20% silk, 20% polyamide (nylon)
HOOK 2-3mm
RRP £17.99

As a blend of cotton, viscose, silk and nylon, Japanese yarn Noro Sonata has outstanding stitch definition and a subtle sheen. The superfine fingering weight is available in a range of vivid hues, making it perfect for standout pieces such as lacework wraps and stoles. True to Noro's



03

philosophy, Sonata celebrates nature's irregular beauty, using fibres from certified organic farms and employing eco-conscious methods to spin a textured yarn. Crocheting with this sustainable, stylish yarn is a mindful experience.

www.noroyarns.com

COPENHAGEN FIBERS
BABY ALPACA BLEND

WEIGHT Aran
BALL 50g/100m
PRODUCT 50% alpaca, 35% cotton, 15% wool
HOOK 6mm
RRP £8

Lovingly made in Italy, this super-soft yarn is a snuggly blend of alpaca, cotton and wool, working up into a fabric with a delicate, fuzzy halo. Exceptionally smooth and itch-free against the skin, it's perfect for stylish heirloom garments you'll treasure for years



05

to come. Its gentle texture and cosy feel make it ideal for crochet projects that call for comfort and snuggliness. Whether you're crafting a timeless jumper or a cherished wrap, Baby Alpaca Blend creates warmth and luxury with every stitch.

www.hobbii.co.uk

YARNSMITHS HAND DYE
MERINO SOCK

WEIGHT 4ply
BALL 100g/400m
PRODUCT 25% nylon, 75% wool
HOOK 3mm
RRP £15

Made from 75% Australian Merino wool, this pillow-soft yarn makes turning a heel a treat. It comes in a selection of variegated shades, featuring short and sweet colour changes in lip-smacking shades such as Strawberry Tart, Birthday Cupcake and Raspberry Parfait.



02

It's superwash-treated for hassle-free care, and its breathable, antibacterial properties make it ideal not only for socks but also for any lightweight garments worn next to the skin. For best results, wash at 30°C and dry flat.

www.woolwarehouse.co.uk

JAMES C BRETT
COTTON WAVES

WEIGHT DK
BALL 100g/210m
PRODUCT 100% cotton
HOOK 4mm
RRP £3.75

This vibrant 100% cotton DK yarn brings playful energy to projects, with 210 metres in each great-value cake. Its gorgeous colour transitions come in a range of shades, such as the blue-toned Water's Edge, vibrant purple, green, red and blue in Fruit Jelly, and the pink, red and



04

purple of Spring Smile. The yarn's smooth texture glides easily through your hook, creating breathable, lightweight fabric with excellent stitch clarity. Machine washable at 30°C and tumble dryable on low, it's as practical as it is cheerful.

www.jamescbrett.co.uk

CYGNET
COLOUR RUSH DK

WEIGHT DK
BALL 100g/360m
PRODUCT 100% acrylic
HOOK 4mm
RRP £3.69

Bold transitions in tonal shades make Cygnet Colour Rush a tempting addition to your stash. These eye-catching swirls create striking self-stripping patterns in your projects, whether you're crafting a cosy garment or homeware accessories. The vibrant colour



06

changes are a joy to watch unfurl as your project grows, with 16 shades to choose from. Practical as well as beautiful, this yarn offers great value and is machine washable for easy care – just the thing for everyday makes with a splash of personality.

www.cygnetyarns.com



Fred. Olsen Cruise Lines

EXCITING ADVENTURES AWAIT

Cruise Collective Members can benefit from up to
£200pp On-Board Spend on most Fred. Olsen Cruises



Join us on one of our specially timed Northern Lights cruises from convenient UK ports and experience the magic of the Arctic. Witness nature's greatest light show as ribbons of green, blue and pink dance across Norway's landscapes of remote islands, towering mountains and shimmering glaciers.

What makes these sailings even more special is the chance to learn from the experts at Go Stargazing, who will be on board to host informal and informative sessions on our open decks.



CRUISE COLLECTIVE

**PLEASE CALL 0800 0355 144
QUOTING CCOL25A**



GO STARGAZING



Scan the QR code to find out more

Terms and conditions apply: The On Board Spend affinity benefit is valid for new bookings made from 1st March 2025 to 31st March 2026 cannot be applied retrospectively and is not combinable with any other discounts or offers including our Oceans Loyalty Club scheme or any group deals. The On-Board Spend affinity benefit amount varies depending on the cruise duration (cruises of 5 nights or less £50 pp, 6 – 10 nights or less £100 pp, 11 – 15 nights or less £150 pp, 16 nights or more or less £200 pp). Applicable to selected sailings. FOCL reserve the right to exclude any cruises from this affinity scheme at any time without prior notice. You will need to provide your Cruise Collective affinity booking code and Cruise Collective membership number at the time of booking and evidence of this membership may be required at embarkation. On Board Spend is automatically applied to your on-board ship account and cannot be transferred, refunded or exchanged for cash. Visit www.fredolsencruises.com/legal/terms-and-conditions for full t&c's. E&OE.

Show us yours

JOIN OUR GANG OF TREBLE MAKERS AND SHARE YOUR THOUGHTS AND MAKES WITH US,
♥ FOR A CHANCE TO BE FEATURED HERE, USE OUR HASHTAG #SCTREBLEMAKER ♥



SAFARI STYLE

Following an acquired brain injury, Emma Jane was supported by a charity and is now a trustee. The support worker who helped her through is expecting a baby, so Emma stitched this gorgeous giraffe blanket to match her safari-themed nursery. What a lovely gesture! [f](#)

VALIANT VAMP

Susan Houghton made this adorable vampire, christened Louis, for her grandchild who recently started university. "I thought it would be a nice surprise," she told us. "Something to brighten up their room." We love his cheeky little smile and blood-red fangs! Find the pattern in issue 167. [f](#)



DOUBLE TAP ♥

We've been double tapping on Instagram and admiring your makes. Tag us @simplycrochetmag and use the hashtag #SCTreblemaker [i](#)



YOKE'S ON YOU!
[@bethwatersart](#) put her own twist on the autumn cardi from issue 166. "I'm pleased with the outcome and get compliments on it!" she tells us.



SKULL SKILLS
[@margieelisabeths](#) world has been busy with our 2025 festival dolls, gifting them to people from the countries depicted. Here's her Day of the Dead doll.



SPOOKY HOOKS
"I adore this pattern by Pony McTate!" says [@lisapinenotes](#). Lisa was married on 31 October, which is also her father's birthday. "I wear this every year to celebrate."



SPIKE UP YOUR LIFE
[@craftymirla](#) tagged us in this adorable photo of her cactus pin cushion, as seen in issue 59. No way that was eight years ago! Those are seriously cute stitches.

COUNTING SHEEP



Nikky Younani emailed in to show us her sheep motif baby blanket from issue 125, designed by Ana Moraes Soares. "I made this for my cousin's second baby who runs her own lamb farm with her partner," Nikky tells us. "I hope you like it. I really enjoyed making it." We're pleased to hear it, Nikky – and we do like it! What a lovely and meaningful gift. [@](#)

FIND MORE PROJECT INSPIRATION AT
gathered.how/crochet-shop

- Download patterns from Simply Crochet
- Order back issues
- Amigurumi
- Garments
- Blankets
- Upcycling
- And more!

MUST-HAVE
PATTERNS!



ORANGE CRUSH

You lot loved Cassie Ward's retro cotton T-shirt – and we loved seeing yours! This lovely orange and brown version was stitched by @perga_rinsky. "This was very fun to crochet!" she posted. "Except when I assumed it was US abbreviations and had to restart everything after quite a few hours of work..." Easily done – we've all been there! It was worth persevering for those gorgeous results. Find the pattern in issue 164.



TAKE 1,000s OF PATTERNS WHEREVER YOU GO!



* Search for Simply Crochet on your chosen app store

Available on Apple, Google Play, Zinio and Nook

iPad is a trademark of Apple Inc., registered in the U.S. and other countries. App Store is a service mark of Apple Inc. NOOK is a registered trademark of Barnes & Noble, Inc. NOOK Tablet is a trademark of Barnes & Noble Inc. *Free trial is for new users on annual subscriptions only. Cancel at any point during the trial to avoid being charged. Free trial not available on Zinio.

DOGGED DETERMINATION

Here's Emma Hedges' little dog from our October 2025 issue. We love the cute raised eyebrows – talk about puppy dog eyes! If you fancy making your own, the pattern can be found in issue 167. Or have you made an ami' pup already? Let us know!





JOIN US ONLINE!

If you're looking to socialise with like-minded crocheters, then make sure you join our SCTreblemakers Facebook group – *the* place to share pictures of your makes, get pattern recommendations and advice, and generally talk about how much you love *Simply Crochet* magazine. With over 7.5k members, it's a bustling crochet forum full of friendly fellow hooksters. We look forward to chatting with you on there!



- ## TALK TO US!
- Post a pic on our Facebook page facebook.com/groups/sctreblemakers
 - Tweet us @SimplyCrochet_ x.com/SimplyCrochet_
 - Add to our Finished Projects board ravelry.com/groups/simply-crochet
 - Use the hashtag #SCtreblemaker instagram.com/simplycrochetmag
 - Email us at: simplycrochet@ourmedia.co.uk



FREE TRIAL*



CROCHET *Unravelled* With Becky Skuse

WHAT CAN I MAKE WITH MY YARN SCRAPS?

Brush up on your technique with our simple guide...

For any crocheter with a stash of yummy yarn, there's always a problem: what to do with all those little odds and ends of yarn, often left over from old projects. Well, we have the perfect idea for using up those random little balls and creating some unique, colourful projects: tie them together! The easiest way to do this is with a 'magic knot', and in this workshop we'll show you how to perform this clever little trick.

The magic knot is a way to join together two pieces of yarn with a super-strong knot that won't come undone and that doesn't leave any ends to weave in – result! You can use this knot

to join together as many little scraps as you like, in whatever colour theme or combination you like, to create your own brand new ball of yarn. The magic ball will look similar to a shop-bought variegated yarn and will hook up into a unique and excitingly unpredictable colour effect.

The magic knot is a really handy and easy technique that's worth learning, even if you only use it to join a new ball of the same yarn on a bigger project. We'll explain just what you need to do and how to do it, so you can work secure knots and create your own colourful yarn balls. Let's do it...



HOW DO I GET STARTED?

It's so easy to start off a magic knot...

To make a colourful yarn ball (magic ball), you'll need to use a magic knot to tie all of the yarn scraps together. Make sure all of the yarn scraps that you are using are of the same weight.

To practise making a magic knot, you need two pieces of scrap yarn – each one should be at least 20cm long. We used DK yarn in cream (Yarn A) and pink (Yarn B). You might also find it useful to have a crochet hook and tapestry needle to hand in case you need to use them for taming any tricky bits.

Step 1 Start by placing Yarn A (cream) onto your work surface, with the end on the left. Then place Yarn B (pink) below it, with the end on the right. Take Yarn A and place it over Yarn B, pointing downwards.

Step 2 Next, take the end of Yarn A behind both Yarn A and Yarn B, pointing upwards.

Step 3 Take the end of Yarn A and insert it from front to back into the loop of Yarn A that you've made. This step can be a bit fiddly, so take your time and use a crochet hook or tapestry needle to help if you need it.

Step 4 Pull on both ends of Yarn A to tighten the knot. You will have made a strong knot over Yarn B and you'll be ready to move on to the next steps.

Tip If your scraps are short, or you want as much as possible of a colour available for working with, tie the knots as near to the ends as you can manage.

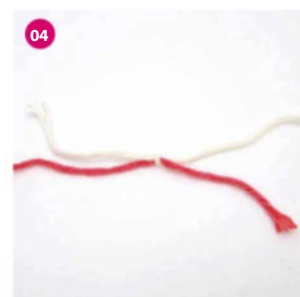
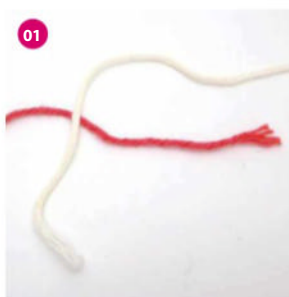

HOW DO I FINISH THE MAGIC KNOT?

Finish off the knot with some simple know-how...

Step 1 Slide the Yarn A knot up Yarn B slightly so that you've got plenty of Yarn B to work with.

Step 2 Place the end of Yarn B over Yarn A, pointing upwards.

Step 3 Pass Yarn B behind Yarn A and then in front of Yarn B, pointing downwards.

Step 4 Pass Yarn B behind the loop of Yarn B and insert it into the loop so the end of Yarn B comes out the front of the loop.

Step 5 Pull on both ends of Yarn B to tighten the knot.

Step 6 Pull on the working ends of Yarns A and B to bring the two knots together.

Step 7 Trim the ends off the knot, taking care not to cut any of the yarn from the knot itself.

Step 8 The finished knot is strong and small, and best of all, there are no ends to weave in!

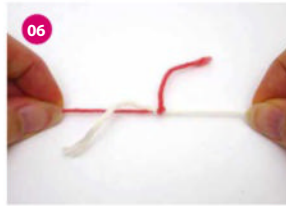

HOW DO I MAKE A MAGIC BALL?

Create stash-busting colour effects...

Once you can work a magic knot, you'll see that there are plenty of potential uses for it in your projects, especially where there are lots of colour changes. One of the most exciting uses for the magic knot is to make magic balls and create your own colour effects. You could use this method on the rug on page 52.

Step 1 Decide on the order that you want the colours to be

joined together. We've gone for a rainbow effect.

Step 2 Join the yarns together in the arranged order, using the magic knot technique. You can then wind them into one colourful ball to use as normal.

Step 3 A small ball could be used to make a lacy bookmark.

Step 4 A larger ball could make a rainbow cowl or scarf.

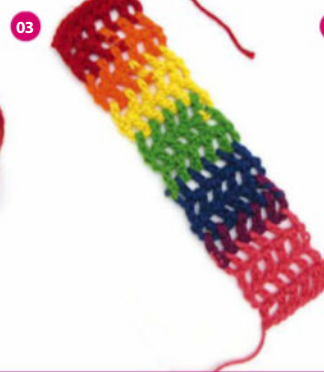

Let us solve your hooky conundrums!

Crochet Unravelled aims to dive deep into the techniques, tutorials and terminology that will make you a better hookster. Have you got a question you want us to unravel? Send it in to us at simplycrochet@ourmedia.co.uk

NEXT ISSUE

Don't miss the next workshop... I'll show you how to make lovely filet crochet

NEXT ISSUE



MODERN CHINTZ



LOVELY ROSE CUSHION

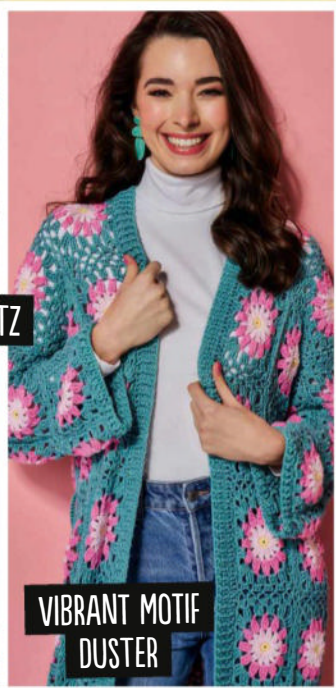

VIBRANT MOTIF DUSTER

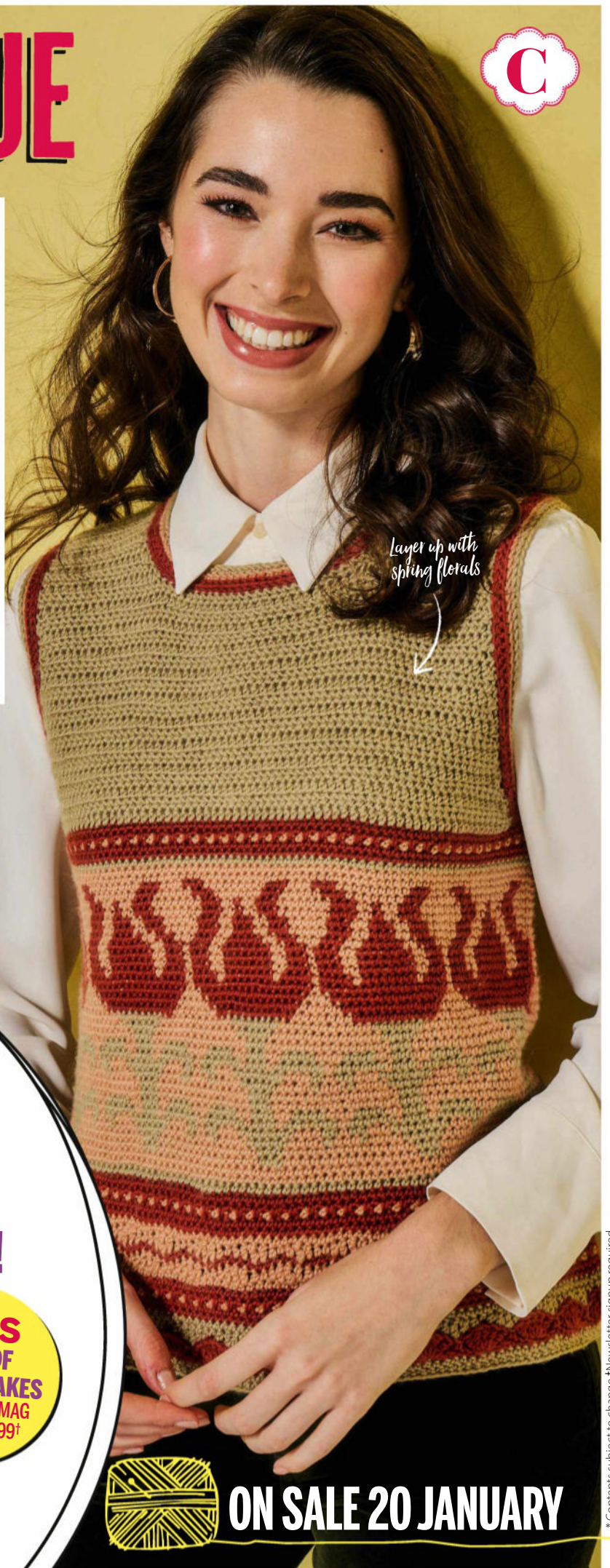

PLUS

- * Toy fox * Penguin blanket
- * Stylish jacket * Snug cowl
- * Tunisian throw and MORE!

EXTRA!
Just for you
**BONUS PATTERNS
FOR VALENTINE'S DAY!**



**PLUS
BEST OF
MOLLIE MAKES
BONUS DIGI MAG
WORTH £9.99†**



ON SALE 20 JANUARY

* Contents subject to change. † Newsletter sign-up required



Crochet essentials

Over the next few pages, you'll find simple step-by-step guides to many useful stitches and techniques that you'll use every time you pick up a hook

HOLDING THE HOOK

Try these methods and see which works best



PENCIL METHOD

Hold the hook like a pencil, in your right hand (if you're right-handed), about 3-5cm from the hooked end. If your hook has a flat area, you'll find it comfortable to hold it here.

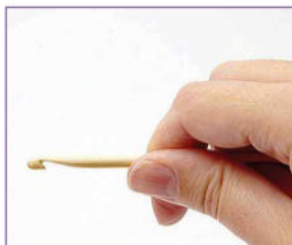

KNIFE METHOD

Hold the hook between your thumb and forefinger, about 3-5cm from the hooked end, resting the end of the hook against your palm. This will give you lots of control.

HOLDING THE YARN

Even tension results in even stitches



METHOD ONE

Pass the ball end of the yarn between the little finger and third fingers of your left hand (if you are right-handed), then behind the third and middle fingers, over your index finger.

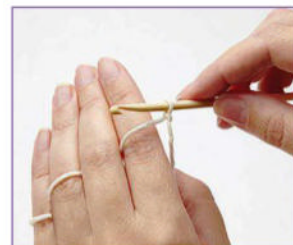

METHOD TWO

Loop the ball end of the yarn loosely around the little finger of your left hand, then take it over the third finger, behind the middle finger and over your index finger.

MAKING A SLIPKNOT The first loop on the hook



1 Hold the tail of the ball of yarn in your left hand and drape the yarn clockwise over the top of it to form a loose, circular loop.



2 Hold the loop between left thumb and forefinger, then insert the crochet hook through the centre of the loop from front to back.



3 Catch the ball end of the yarn with the hook and pull it back through the centre of the loop, taking the yarn through with it.



4 Pull both ends of the yarn to tighten the knot, then pull just the ball end to tighten the loop so it's close to the hook, but not touching it.

CHAIN STITCH Use this stitch to make your foundation chain

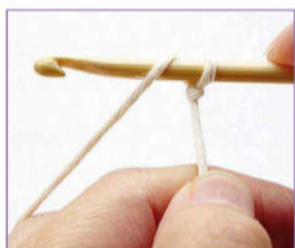

1 Hold the hook in your right hand, and both the yarn end and the working yarn in your left hand. Move the hook under and over the yarn to wrap it around anticlockwise.



2 Pull the hook towards the slipknot, catching the yarn in the hook, and pulling it through the slipknot loop. This forms your first chain (ch) stitch. Repeat steps 1 and 2 to form a chain length.



3 This is what your row of chains will look like. Hold the chain with your left hand near the hook, to keep the tension. Keep going until you have the number of chains that's stated in your pattern.

How to count chains



Each chain or loop counts as one stitch. Never count your first slipknot or the loop on the hook (called the working loop). So that you can be accurate, make sure the chain is not twisted and that the front is facing you.

SLIP STITCH (ss)

This stitch has no height – often used to join rounds



1 You can make a slip stitch in any chain or stitch, to join it to the working loop on the hook. To make a slip stitch, simply insert the hook into the stitch indicated, from front to back.

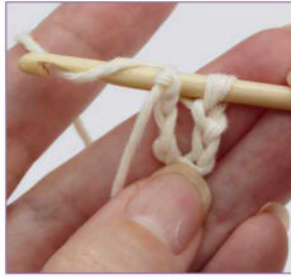

2 Catch the ball end of the yarn with the hook, so the yarn wraps anticlockwise around it (yarn round hook, or yrh).

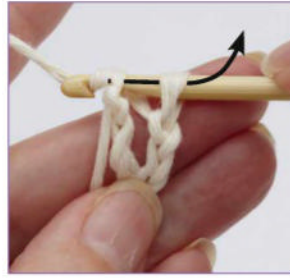

3 Gently pull the hook, and the yarn wrapped around it, back towards the 2 loops on the hook. Draw the yarn through both the loops on the hook.



4 This will finish the stitch and you'll see how the slip stitch has joined the working loop to the chain or stitch you inserted the hook into. You can also use slip stitch to form a neat edging.

DOUBLE CROCHET (dc) US term: single crochet

One of the key stitches in crochet, doubles are simple, compact stitches that form a dense fabric



1 To make a double crochet stitch, insert the hook under the top 2 loops of the next stitch on the previous row.



2 Wind the yarn around the hook (yrh).



3 Pull the yarn through the stitch, giving you 2 loops on your crochet hook.



4 Yarn round hook again, then pull the yarn through both loops. There's your double crochet made and you'll have one loop left on the hook, ready to do the next stitch.

HALF TREBLE CROCHET (htr) US term: half double crochet

A handy stitch that's between double and treble crochet in size, and it looks slightly looser than double crochet



1 To make a half treble crochet stitch, work to where you want the htr and then wind the yarn round the hook (yrh).



2 Insert the hook under the top 2 loops of the next stitch in the previous row. Wrap yarn around the hook again (yrh).



3 Pull the yarn through the stitch only (3 loops on hook).



4 Yarn round hook again, pull the yarn through all 3 loops. You've made a half treble crochet. Continue working htr into next and following sts to the end of the row.

TREBLE CROCHET (tr) US term: double crochet

One of the most popular stitches in crochet, this simple stitch is twice as high as a double crochet stitch



1 To work a treble crochet, start by winding yrh and then insert the hook under the top 2 loops of the stitch on the previous row.



2 Wrap the yarn around the hook (yrh) and pull the yarn through the stitch only.



3 You will now have 3 loops on the hook. Yrh again, and draw the yarn through just the first 2 loops on the hook.



4 You will now have 2 loops on the hook. Yrh again and draw the yarn through the remaining loops on the hook. Your treble crochet is complete.

WORKING IN ROWS

Follow these simple rules to construct crochet fabric



1 The first row is made by working across the foundation chain from right to left. At the end of the chain or row, turn the work so that the yarn is behind the hook.



2 For the next row, first make the turning chain for the stitch you're about to work (see opposite). Now work the next stitch into the top of the stitches on your first row, missing the first stitch.

WORKING STITCHES INTO A RING

To make circles, tubes and other shapes



1 Make a foundation ring and work the t-ch (3ch for treble sts). Work a treble st as usual, but insert hook into centre of ring. For treble sts, yrh, insert hook into ring.



2 Finish the treble, as usual (yrh, pull yarn through ring, yrh, pull yarn through first 2 loops, yrh, pull yarn through 2 loops). Work more sts into the ring as needed.

DOUBLE TREBLE CROCHET (dtr) US term: treble crochet

This is a stitch regularly used as an elongated version of the treble (described above). It's worked in a very similar way to the treble, as follows:

- 1** Make a foundation chain. Skip 4ch, *yrh twice, and insert the hook under the top loop of the next ch.
- 2** Yrh, pull the yarn through the ch loop only (4 loops on hook).
- 3** Yrh and pull the yarn through 2 loops only (3 loops on hook).

Yrh and pull the yarn through 2 loops only (2 loops on hook).

- 4** Yrh and pull the yarn through the remaining 2 loops. Repeat from * to make more dtr sts.
- 5** To make the next row of dtr, turn work and ch4. This turning chain counts as the first dtr in a new row. Skip first st at the base of the t-ch, work 1dtr under the top 2 loops of the second stitch in the previous row; continue to the end of the row.

TRIPLE TREBLE CROCHET (ttr) US term: double treble crochet

This is one of the longest standard crochet stitches and is mainly used in fancy stitch patterns. It's taller than a double treble crochet stitch (described left) and is worked in a very similar way, as follows:

- 1** Make a foundation ch. Skip 5 ch, *yrh 3 times, insert hook under top loop of next ch.
- 2** Yrh, pull yarn through ch loop only (5 loops on hook).
- 3** † Yrh, draw loop through

2 loops only. Repeat from † 3 times more and your triple treble will be finished. Repeat from * to make more ttr sts.

- 4** To make the next row, turn work and ch5. This turning chain counts as the first triple treble in a new row. Skip first st at base of the t-ch. Work 1 triple treble, inserting hook under the top 2 loops of the second st in the previous row; continue to the end of the row.

Abbreviations

across	to end of the row	meas	measures
approx	approximate(ly)	patt(s)	pattern(s)
beg	beginning	pm	place marker
bl	insert hook under back loop only	prev	previous
BP	Back Post: work st indicated, inserting hook around post of st from back to front to back and not in top of st	qtr	quadruple treble
ch(s)	chain/chain stitch(es)	rem	remain(s)/remaining
ch-	refers to ch made previously, eg. ch-3	rep	repeat
ch-sp(s)	chain space(s)	RH	right hand
cl(s)	clusters	rnd(s)	round(s)
cont	continue	RS	right side
dc	double crochet	sk	skip
dc2tog	(insert hook in next st, yrh & draw a loop through) twice, yrh & draw through all 3 loops on hook	sp(s)	space(s)
dec	decrease	ss	slip stitch
dtr	double treble crochet	st(s)	stitch(es)
dtr2tog	work 2dtr together	t-ch(s)	turning chain(s)
fdc	foundation dc	tog	together
fl	insert hook under front loop only	tr	treble crochet
fol/folls	following/follows	tr cl	(yrh, insert hook in sp/ st, yrh & pull up loop, yrh & draw through 2 loops) number of times indicated, yrh & draw through all loops on hook
FP	Front Post: As BP, inserting hook around post from front to back to front	tr2tog	(yrh, insert hook in next st, yrh & pull up loop, yrh a& draw through 2 loops) twice, yrh & draw through all loops on hook
ftr	foundation tr	ttr	triple treble crochet
htr	half treble	WS	wrong side
htr2tog	work 2htr together	yrh	yarn round hook
in next	sts to be worked into the same stitch	*	work instructions immediately foll *, then rep as many more times as directed
inc	increase	()	work all instructions in the brackets as many times as directed
LH	left hand		
lp(s)	loop(s)		

Crochet hook conversions

UK	METRIC	US
14	2mm	-
13	2.25mm	B/1
12	2.5mm	-
-	2.75mm	C/2
11	3mm	-
10	3.25mm	D/3
9	3.5mm	E/4
-	3.75mm	F/5
8	4mm	G/6
7	4.5mm	7
6	5mm	H/8
5	5.5mm	I/9
4	6mm	J/10
3	6.5mm	K/10½
2	7mm	-
0	8mm	L/11
00	9mm	M/13
000	10mm	N/15

Which hook do I use?

Hook size	UK yarn weight
2.5-3.5mm hook	4ply yarn
3.5-4.5mm hook	double knitting yarn
5-6mm hook	aran yarn
7mm and bigger	chunky yarn

UK/US conversions

UK		US	
chain	ch	chain	ch
slip stitch	ss	slip stitch	ss
double crochet	dc	single crochet	sc
half treble	htr	half double	hdc
treble	tr	double	dc
double treble	dtr	treble	tr
triple treble	ttr	double treble	dtr



LEARN MORE ON OUR WEBSITE

Scan here to go directly to our page on www.gathered.how



Find out everything you need to know about crochet on Gathered! Our page is filled with step-by-step videos, useful how-tos and information on the tools you'll need. Learn techniques such as how to create a turning chain, change colour, increase and decrease, sew seams, check your tension, make a magic loop, join your rounds and much more. And while you're there, have a look at our free crochet patterns – you may just find your next make!

Learn something new with gathered.



Boost your skills with...

- **FREE** how to guides and expert advice
- **FREE** video tutorials that help you every step
- **FREE** craft classes
- **FREE** seasonal patterns



www.gathered.how

CHARTS & DIAGRAMS

Use these charts and diagrams to make the leluja blanket, wall hanging, dots & dashes blanket and granny square scarf

- Key**
 Yarn A
 Yarn B

Leluja blanket, page 40

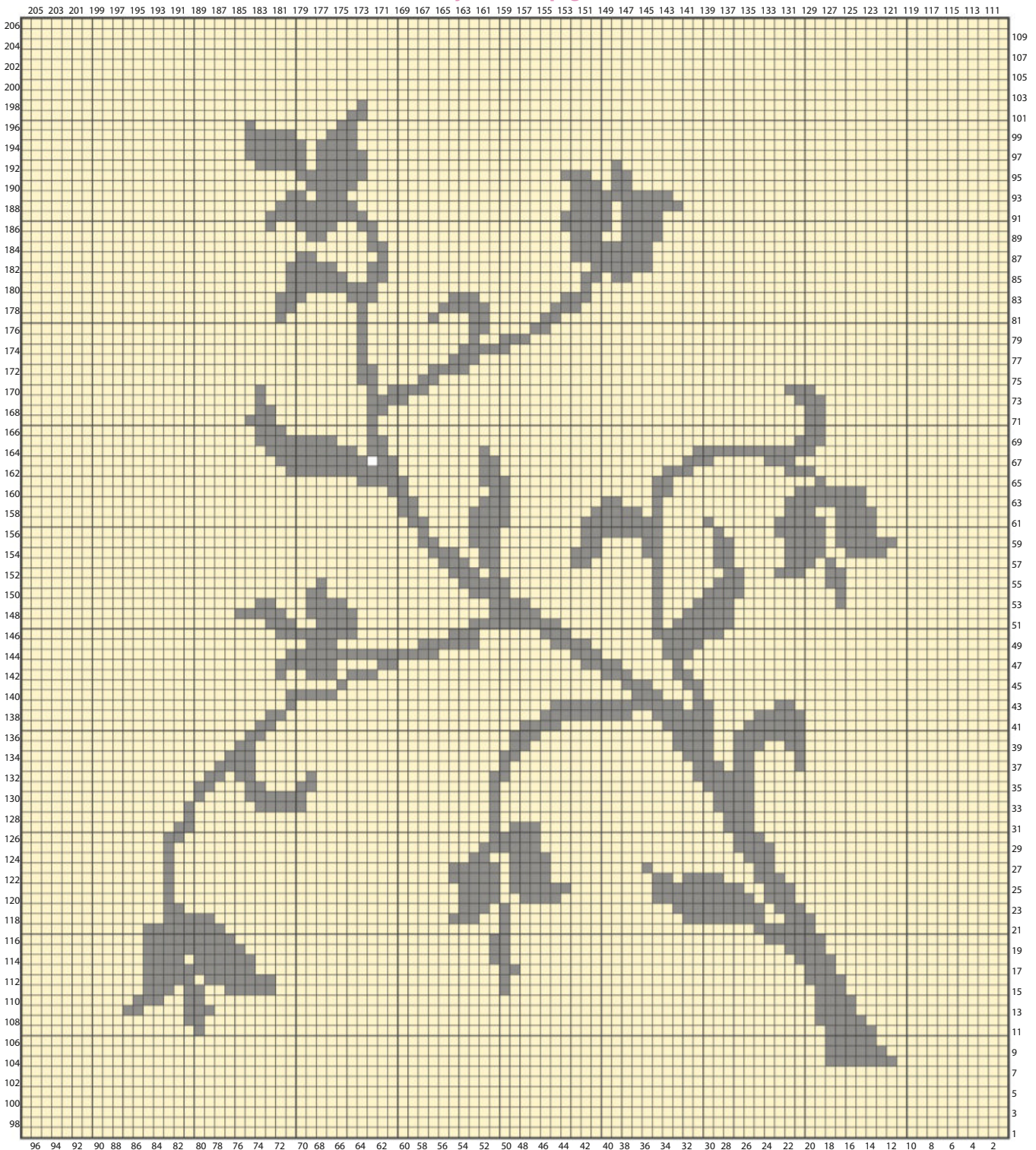

CHARTS

Mod girl wall hanging, page 22

Key

- White
 - Black
 - Red
 - X Tr2d
 - + Dc in both loops
- *Row 1 begins here



Need a bigger chart?

Scan the QR code to download the chart, or visit www.gathered.how/crochet-charts

Dots & dashes blanket, page 24

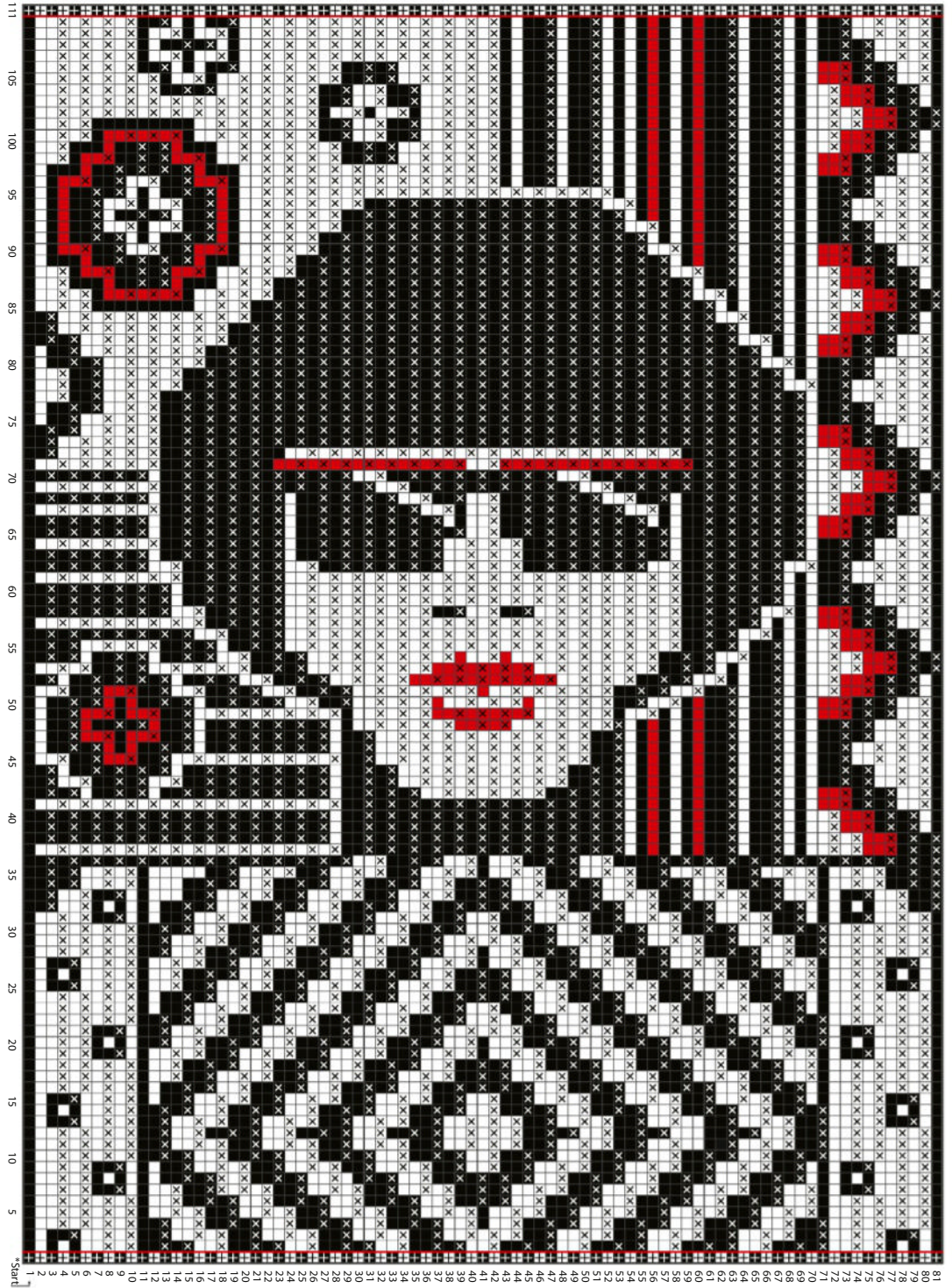
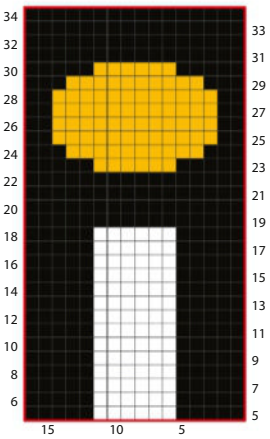

Key

- Yarn A
- Yarn B
- Yarn C

Granny square scarf, page 20





Street style

Six reasons to follow Calvin from @calfunnnnn for modern, wearable takes on the classic granny square

Instagram: @calfunnnnn
Followers: 183K



IF YOU LIKE... mixing up your style, take a look at Calvin's profile. "My design style is a mix of nostalgia and modern creativity," he says. #OldSchoolCool



IF YOU WANNA... broaden your horizons, Calvin's your guy: "I share how crochet can go beyond blankets and become fashion you can live in." #CosyUp



IF YOU HAVE... eclectic taste, Calvin's the same. "I pull inspiration from everywhere. If it catches my eye, it might turn into a cardigan." #CreativeThinking



IF YOU NEED... a mood boost, Calvin is an advocate for the joy crochet brings. "I love the rhythm of it. It's both calming and creative." #YarnOnTheBrain



IF YOU ARE... prone to changing your mind, it's all part of the process for Calvin: "I love planning the overall vibe, but I also go with the flow." #OneStitchAtATime



IF YOU LOVE... making granny squares, you're not alone! Follow Calvin for inspo around colour, texture, and stitching pieces you're proud to wear. #IMadeThis

IT'S ALL OVER...

Trending this month on Instagram
♥ EMOTIONAL SUPPORT PICKLES ♥



@kjrb_stitching_corner pattern
by @amisbyangele
@mainstreetwishco adapted
pattern by @babycakesstudios



Big DARLING

A super big and squishy yarn!

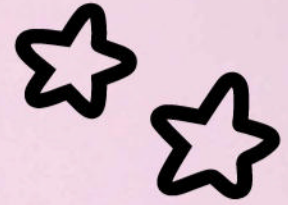

Super Chunky
Weight

150 g
=
90m

15
Bold Uni
Colours!



100%
Polyester



Discover Big
Darling now —
scan the QR
code!

- Soft, chenille texture
- Perfect for cosy home decors and XL amigurumi
- OEKO-TEX® & EN71-3 certified



HOMESPUN ARAN

Earth-spun simplicity—
with nature's gentle touch.

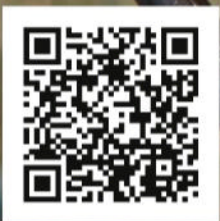

KNIT • FOLLOW • SHARE

01756 703 670 kingcole.com enquiries@kingcole.com



MISSED AN ISSUE?

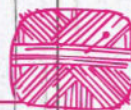

ISSUE 169

Our cover star is glittery textured yoke sweater, perfect for parties! See Christmas in a new light with our Technicolour Tinsel collection, which includes a wreath, tree skirt and baubles in vibrant shades. Stitch a snowman pal, embellish a children's jumper, get cosy in sparkly socks, and read our expert advice on managing your Christmas crochet projects. All this and more!

SEE OUR BACK
ISSUE PROJECTS IN
DETAIL ON RAVELRY
[BIT.LY/RAVSIMPLYC](https://bit.ly/RAVSIMPLYC)



RETURN TO THE APP TO BUY YOUR BACK ISSUES

All issues of *Simply Crochet* are available as digital editions, ready to read whenever you want. Every purchase is permanently stored in your magazine library. Once your magazine has downloaded, an internet connection is not required, so you can take your magazine with you wherever you go.

EVERY ISSUE IS AVAILABLE DIGITALLY, STARTING FROM ISSUE ONE!



ISSUE 168

Granny stripe jumper, plaid tidings collection, reindeer onesie, baby Fair Isle cardi, cushion, cowl, festive earrings.



ISSUE 167

Ami' vampire, Bauhaus cardigan, cat cushion, mitred bag, William Morris collection, sloth cushion, little puppy.



ISSUE 166

Striving collection, spots and stripes shawl, ami' mushroom, Halloween bunting, granny cardi, geometric blanket.



ISSUE 165

Hexagon collection, halterneck top, ami' toucans, lattice scarf, sandal straps, fish bag, star blanket, filet vest.



ISSUE 164

Retro tee, cute cuisine collection, halterneck top, sunset shawl, ami' hedgehog, jeans trim, mitred bag, table tray.



ISSUE 163

Geometric top, Loops & Lines collection, ami' Dean & Nala, krajka belt, flower bag, toy hippo, storage baskets.



ISSUE 162

Bright cardi, joy of making collection, ladybird throw, ami' bunny, lace shawl, mini bag, bee keyring.



ISSUE 161

Yoga collection, ami' frog, rooster rug, baby play mat, butterfly cushion, mini poncho, diamond blanket.



ISSUE 160

Games collection, slouchy top, floral blanket, hat & scarf, daffodil posy, unicorn ami', pastel pullover.



ISSUE 159

Brit Pack collection, wavy yoke sweater, giraffe ami', rainbow bag, flower cushion, placemats, blanket.



ISSUE 158

Dine in collection, fleck jumper, fur trims, giant cushion, sparkly shawl, wallhanging, ami' whale, blanket.



ISSUE 157

Lounge collection, shawl, check tank, blankets, plaid jacket, penguin toy, bag, hat & scarf, cushion.



ISSUE 156

Festive collection, bunny ami', check cardi, star jumper, tea light house, tree ami', Santa beard.



**5 EXCLUSIVE
PATTERNS
FOR YOU!**

WINTER HATS!

Cosy accessories
for all the family

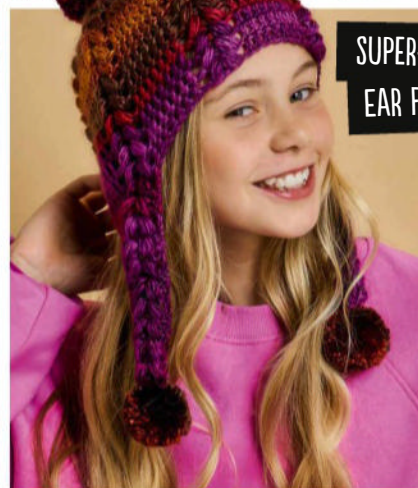

CONTENTS

5 BOBBLE HAT

A timeless classic for all the family

8 EARFLAP HAT

You heard it here first – the trapper hat is in

10 TAM O' SHANTER

A crochet twist on the Scottish accessory

12 DOUBLE BOBBLE HATS

Two pompoms are better than one!

15 SLOUCHY HAT

Lean into this lovely laidback look

17 HOW TO MAKE A POMPOM

A must-know method for hat enthusiasts

18 WALKTHROUGHS

Step-by-step tutorials to help you



WINTER HATS!



Here we are in January – not exactly my favourite time of year. You know what will make it better? Crochet, and lots of it! Whether you treat yourself to a new beanie or go all-out with a matching set for the family, we're confident you'll love the five different styles featured in this bonus magazine.

And if you've got your mitts on a pompom maker, you'll know the soothing effects of winding yarn around... and around... and around. I've changed my mind. I love January! Just don't look at my hat hair...

Sara

Editor, *Simply Crochet*



**MADE WITH
FIVE DIFFERENT
SCHEEPJES
YARNS!**
Available now from
www.scheepjes.com





Beanie and done

A lush lilac cap with toasty texture and finished with a pom-pom,
ready to stitch and style in two sizes



YOU WILL NEED

- Scheepjes Chunky Monkey (100% acrylic, 100g/116m)
2 balls of Heather (1724)
- An 8mm (US L/11) hook
- A pompom maker

For yarn stockists contact
Scheepjes

www.scheepjes.com/en

TENSION

12 sts and 10 rows to measure
10x10cm (4x4in) over rib pattern
using an 8mm hook, or size needed
to obtain correct tension

MEASUREMENTS

Child Hat measures approx 46cm
(18in) in circumference around
brim Adult Hat measures approx
52cm (20½in) in circumference
around brim

ABBREVIATIONS

For a full list, see page 78 of
Simply Crochet magazine

Hot take: anyone can wear a bobble hat. Mums, dads, children and friends – this is your cue to make a matching set!

NOTES

Hat is worked in vertical rows, then seamed to form a tube. The top is gathered before adding a pompom.

The rib pattern is worked across the first 8 sts on each RS row and last 8 sts on each WS row. Measure along this edge when checking your tension.

The pattern is written in 2 sizes: child and adult. Instructions for the child size are written first, with the adult size in brackets. You can easily adapt the finished size by working more or fewer rows in the pattern.

Each Hat requires approx 1.5 balls of yarn so you can make 2 Hats using 3 balls.

BOBBLE HAT

Using Heather, ch29 (33).

Row 1 (RS) Ss in second ch from hook, ss in next 11 ch, (htr in next 4 ch, ss in next 4 ch) twice, htr in last 0 (4) ch, turn. [28 (32) sts]

Row 2 (WS) Ch1 (does not count as st throughout), htr in first 0 (4) sts, ss in next 4 sts, (htr in next 4 sts, ss in next 4 sts) twice, dc in last 8 sts, turn.

Row 3 Ch1, ss in first 8 sts, (htr in next 4 sts, ss in next 4 sts) twice, htr in next 4 sts, ss in next 0 (4) sts, turn.

Row 4 Ch1, ss in next 0 (4) sts, htr in next 4 sts, (ss in next 4 sts, htr in next 4 sts) twice, dc in last 8 sts, turn.

Row 5 Ch1, ss in first 12 sts, (htr in next 4 sts, ss in next 4 sts) twice, htr in last 0 (4) sts, turn.

Row 6 Ch1, htr in next 0 (4) sts, ss in next 4 sts, (htr in next 4 sts, ss in next 4 sts) twice, dc in last 8 sts, turn.

Repeat Rows 3-6 another 10 (12) times or to desired head circumference minus 2cm.

Rep Row Rows 3-4.

Fasten off leaving a long tail.



Work a rectangle piece, seam it and gather it at the top, then finish it with a fluffy pompom



The textured stitch pattern is created with a combination of slip stitches and half trebles

TO FINISH

With WS facing, whipstitch the side seam together to create a tube.

Weave the tail through the ends of the rows at the top of the Hat and pull tight to close.

Make a pompom and sew securely to the top of the Hat.

Turn up the brim on the RS.

SIMPLE STEPS HOW TO SEW SEAMS



1 Sewing with a tapestry needle is the regular and neat way to join seams. Place pieces of crochet WS together and oversew them as above, using a tapestry needle.



2 To slip stitch a seam, place the crochet pieces RS together. *Insert hook through both edge stitches, yrh, pull through to complete 1 slip stitch; rep from *, keeping the work fairly loose.



3 For a dc seam, place the crochet pieces RS together, or WS together for a visible seam. Work as for slip stitch seam, using double crochet instead of slip stitch.



4 A useful variation on the dc seam, the dc and chain seam is used when you need less bulk and/or greater flexibility in the seam. Work as for the dc seam, but work 1 dc and 1 chain alternately.

Learn something new with gathered.

Boost your skills with...

- **FREE** how to guides and expert advice
- **FREE** video tutorials that help you every step
- **FREE** craft classes
- **FREE** seasonal patterns



All ears

Toddlers and tweens alike will love the colour changes in this cosy winter staple

Puff stitch details





YOU WILL NEED

- Scheepjes Wanderlust
(100% acrylic, 100g/232m)
1 ball of Amsterdam (467)
 - A 4.5mm (US 7) hook
 - A pompom maker
- For yarn stockists contact**
Scheepjes
www.scheepjes.com/en

TENSION

1 pattern repeat and 6 rows
measure 7.5x7.5cm (3x3in) using a
4.5mm hook, or size needed to
obtain correct tension

MEASUREMENTS

Toddler Hat measures approx 40cm
(15¾in) in circumference
Child Hat measures approx 48cm
(19in) in circumference

ABBREVIATIONS

puff st Yrh, (insert hook in st/sp
indicated, yrh and pull up a loop)
4 times, yrh and pull through all
loops on hook, ch1 to close
For a full list, see page 78 of
Simply Crochet magazine

What's that? Sorry, speak up! We can't hear you over how cool this beanie is! Our ears are a tad muffled by all that silky soft yarn...

NOTES

Hat is worked in rounds from the top down.
Earflaps are worked in rows off the final round of the Hat.

EARFLAP HAT

Make a magic loop.

Round 1 (RS) Ch2 (does not count as st throughout), (puff st, ch1) 6 times into loop, ss to top of first puff st. [6 sts, 6 ch-1 sps]

Round 2 (RS) Pull up loop to height of tr, (puff st in puff st, ch1, puff st in ch-1 sp, ch1) 6 times, ss to top of first puff st. [12 sts, 12 ch-1 sps]

Round 3 Ss to first ch-1 sp, pull up loop to height of tr, (puff st, ch1, puff st) in same sp, *3tr in next ch-1 sp, (puff st, ch1, puff st) in next ch-1 sp; repeat from * 4 times more, 3tr in next ch-1 sp, ss to top of first puff st. [30 sts, 6 ch-1 sps]

Round 4 Ss to first ch-1 sp, pull up loop to height of puff st, (puff st, ch1, puff st) in same sp, *2tr in next tr, tr in next tr, 2tr in next tr, (puff st, ch1, puff st) in next ch-1 sp; repeat from * 4 times more, 2tr in next tr, tr in next tr, 2tr in next tr, ss to top of first puff st. [42 sts, 6 ch-1 sps]

CHILD SIZE ONLY

Round 5 Ss to first ch-1 sp, pull up loop to height of puff st, (puff st, ch1, puff st) in same sp, *2tr in next tr, tr in next 3 tr, 2tr in next tr, (puff st, ch1, puff st) in next ch-1 sp; repeat from * 4 times more, 2tr in next tr, tr in next 3 tr, 2tr in next tr, ss to top of first puff st. [54 sts, 6 ch-1 sps]

ALL SIZES

Next round Ss to first ch-1 sp, pull up loop to height of puff st, (puff st, ch1, puff st) in same sp, *tr in next 5 (7) tr, (puff st, ch1, puff st) in next ch-1 sp; repeat from * 4 times more, tr in next 5 (7) tr, ss to top of first puff st to join. [42 (54) sts, 6 ch-1 sps]

Rep last round another 7 (8) times.

[12 (14) rounds worked in total]

Fasten off.

FIRST EARFLAP

With RS facing, join yarn in third tr of any tr group.

Row 1 (RS) Ch3 (counts as tr throughout), tr in next 2 (4) tr, (puff st, ch1, puff st) in next ch-1 sp, tr in next tr, turn. [7 (9) sts]

Row 2 (WS) Ch3, (puff st, ch1, puff st) in next ch-1 sp, tr in next 1 (3) tr, tr2tog, turn. [6 (8) sts]

Row 3 Ch2, skip st at base of ch-2 (counts as dec), tr in next 1 (3) tr, (puff st, ch1, puff st) in next ch-1 sp, tr in next tr, turn. [5 (7) sts]

CHILD SIZE ONLY

Row 4 Ch3, (puff st, ch1, puff st) in next ch-1 sp,



Vertical stripes of puff stitch pairs give the illusion of plaits running the length of the hat

tr in next tr, tr2tog, turn. [- (6) sts]

Row 5 Ch2, skip st at base of ch-2 (counts as dec), tr in next tr, (puff st, ch1, puff st) in next ch-1 sp, tr in next tr, turn. [- (5) sts]

ALL SIZES

Next row (WS) Ch3, (puff st, ch1, puff st) in next ch-1 sp, tr in next tr, turn. [5 (5) sts]
Repeat last row another 1 (4) times.

Next row Ch2, skip puff st, tr in ch-1 sp, skip puff st, tr in last tr.

Fasten off and weave in ends.

SECOND EARFLAP

With RS facing, skip 2 puff st groups around front of Hat, and join yarn last tr before next puff st group.

Row 1 (RS) Ch3, (puff st, ch1, puff st) in next ch-1 sp, tr in next 3 (5) tr, turn. [7 (9) sts]

Row 2 (WS) Ch2, skip st at base of ch-2 (counts as dec), tr in next 2 (4) tr, (puff st, ch1, puff st) in next ch-1 sp, tr in next tr, turn. [6 (8) sts]

Row 3 Ch3, (puff st, ch1, puff st) in next ch-1 sp, tr in next 0 (2) tr, tr2tog, turn. [5 (7) sts]

CHILD SIZE ONLY

Row 4 Ch2, skip st at base of ch-2 (counts as dec), tr in next 2 tr, (puff st, ch1, puff st) in next ch-1 sp, tr in next tr, turn. [- (6) sts]

Row 5 Ch3, (puff st, ch1, puff st) in next ch-1 sp, tr2tog, turn. [- (5) sts]

ALL SIZES

Next row Ch3, (puff st, ch1, puff st) in next ch-1 sp, tr in next tr, turn. [5 (5) sts]
Repeat last row another 1 (4) times.

Next row Ch2, skip puff st, tr in ch-1 sp, skip puff st, tr in last tr.

Fasten off and weave in ends.

TO FINISH

Make 2 small pompoms and secure to each end of the Earflaps.

Male a large pompom and sew to top of Hat.

Bonny blues

The Scottish 'tammie' dates back as far as the 16th century – quite the timeless look!

*Try stacked
trebles!*





YOU WILL NEED

- Scheepjes Colour Crafter
100% acrylic, 100g/300m
1 ball of each:
Yarn A Geraardsbergen (2011)
Yarn B Oostende (2005)
 - A 4.5mm (US 7) hook
 - A pompom maker
- For yarn stockists contact
Scheepjes
www.scheepjes.com/en

TENSION

Rounds 1-4 measures 9cm (3½in) in diameter using a 4.5mm hook, or size needed to obtain correct tension

MEASUREMENTS

Hat measures 48cm (19in) in circumference around head

ABBREVIATIONS

stacked tr Insert hook in first st, yrh and pull up loop, yrh and pull through 2 loops (dc completed), insert hook in left leg of dc (right leg for left-handers), yrh and pull up loop, yrh and pull through 2 loops
reverse dc Insert hook in next st to right (or left if left-handed), yrh and pull up a loop, yrh and pull through 2 loops on hook

For a full list, see page 78 of *Simply Crochet* magazine

The traditional tam o'shanter was stretched on a wooden disc, but you can create a similar shape with some clever crochet tricks.

NOTES

Hat is worked in rounds with RS facing throughout. Change colour on the final yrh of st before colour change is indicated. Carry the unused colour across the top of your sts, enclosing the strand as you work.

TAM O'SHANTER

Using Yarn A, make a magic loop.

Round 1 (RS) Ch2 (does not count as st), 12tr into loop, ss to first tr. [12 tr]

Round 2 (RS) Stacked tr, (change to Yarn B, 2tr in next st, change to Yarn A, 2tr in next st) 5 times, change to Yarn B, 2tr in next st, change to Yarn A, tr in same st as Stacked tr, ss to stacked tr. [24 tr]

Round 3 Stacked tr, (change to Yarn B, 2tr in next 2 sts, change to Yarn A, tr in next 2 sts) 6 times omitting last tr on final rep, ss to stacked tr. [36 sts]

Round 4 Stacked tr, *change to Yarn B, tr in next 2 sts, change to Yarn A, tr in same st as previous tr, tr in next st, change to Yarn B, tr in same st as previous tr, tr in next st, change to Yarn A, tr in next 2 sts; rep from * 5 times more, omitting last tr on final rep, ss to stacked tr. [48 sts]

Round 5 Stacked tr, tr in st at base of stacked tr, *change to Yarn B, tr in next 2 sts, change to Yarn A, tr in next 2 sts, change to Yarn B, tr in next 2 sts, change to Yarn A, 2tr in next 2 sts; rep from * 5 times more, omitting the last 2 tr on final rep, change to Yarn B, ss to stacked tr. [60 sts]

Round 6 Stacked tr, change to Yarn A, tr in same st as stacked tr, *2tr in next st, change to Yarn B, tr2tog, change to Yarn A, tr in next 2 sts, change to Yarn B, tr2tog, change to Yarn A, 2tr in next st, tr in next st, change to Yarn B, tr in same st as previous tr**, tr in next st, change to Yarn A, tr in same st as previous tr; rep from * 5 times more ending final rep at **, ss to stacked tr. [72 sts]

Round 7 Stacked tr, tr in same st as stacked tr, *change to Yarn A, tr in next 2 sts, 2tr in next st, change to Yarn B, (tr2tog) twice, change to Yarn A, 2tr in next st, tr in next 2 sts, change to Yarn B, 2tr in next 2 sts; rep from * 5 times more, omitting the last 2 tr on final rep, change to Yarn A, ss to stacked tr. [84 sts]

Round 8 Stacked tr, change to Yarn B, tr in same st as stacked tr, *tr in next st, change to Yarn A, tr in next 4 sts, change to Yarn B, tr in next 2 sts, change to Yarn A, tr in next 4 sts, change to Yarn B, tr in next 2 sts, change to Yarn A, tr in same st as previous tr**, tr in next st, change to Yarn B, tr in same st as previous tr; rep from * 5 times more ending final rep at **, ss to stacked tr. [96 sts]

Round 9 Stacked tr, *change to Yarn B, tr in next 2 sts, change to Yarn A, tr in next 2 sts, 2tr in next st, tr in next 4 sts, 2tr in next st, tr in next 2 sts, change to Yarn B, tr in next 2 sts, change to Yarn A, tr in next 2 sts; rep from * 5 times more, omitting last tr on final rep, ss to stacked tr. [108 sts]

Round 10 Stacked tr, tr in same st as stacked tr, *change to Yarn B, tr in next 2 sts, change to Yarn A, tr in next 12 sts, change to Yarn B, tr in next 2 sts, change to Yarn A, 2tr in next 2 sts; rep from * 5 times more, omitting last tr on final rep, ss to stacked tr. [120 sts]

Round 11 Stacked tr, tr in same st as stacked tr, *tr in next st, change to Yarn B, tr in next 2 sts, change to Yarn A, tr in next 5 sts, change to Yarn B, tr in next 2 sts, change to Yarn A, tr in next 5 sts, change to Yarn B, tr in next 2 sts; rep from * 5 times more, omitting last 2 tr on final rep, ss to stacked tr. [132 sts]

Round 12 Stacked tr, *tr in next 2 sts, change to Yarn B, tr2tog, change to Yarn A, tr in next 12 sts, change to Yarn B, tr2tog, change to Yarn A, tr in next 4 sts; rep from * 5 times more, omitting last 2 tr on final rep, ss to stacked tr. [120 sts]

Round 13 Ch2, skip first st, tr in next st (counts as tr2tog throughout), *tr in next st, change to Yarn B, tr in next st, change to Yarn A, tr in next 12 sts, change to Yarn B, tr in next st, change to Yarn A, tr in next st, (tr2tog) twice; rep from * 5 times more, omitting last tr on final rep, ss to first tr. [108 sts]

Fasten off Yarn B.

Round 14 Ch2, skip first st, tr in next st, *tr in next 14 sts, (tr2tog) twice; rep from * 5 times more, omitting last st on final rep, ss to first tr. [96 sts]

Round 15 Ch2, skip first st, tr in next st, *tr in next 12 sts, (tr2tog) twice; rep from * 5 times more, omitting last st on final rep, ss to first tr. [84 sts]

Round 16 Ch2, skip first st, tr in next st, *tr in next 10 sts, (tr2tog) twice; rep from * 5 times more, omitting last st on final rep, ss to first tr. [72 sts]

Round 17 Ch2, skip first st, tr in next st, *tr in next 8 sts, (tr2tog) twice; rep from * 5 times more, omitting last st on final rep, ss to first tr. [60 sts]

Round 18 Ch1 (does not count as st), reverse dc in each st around, ss to first st.

Fasten off and weave in all ends.

TO FINISH

Using Yarn B, make a pompom. Sew the pompom to the top of the Hat. Weave in any rem ends.





Double trouble!

What's better than a pom-pom? Two pom-poms! What's better than a double bobble beanie? Two double bobble beanies!

DOUBLE BOBBLE HATS



YOU WILL NEED

- Scheepjes Stone Washed XL (70% cotton, 30% acrylic, 50g/75m)
1 ball of each:
Axinite (871)
Morganite (7021)
Rhodochrosite (875)
Larimar (868)
 - A 5mm (US H/8) hook
 - A pompom maker
- For yarn stockists contact
Scheepjes
www.scheepjes.com/en

TENSION

13 sts and 9 rows to measure
10x10cm (4x4in) over block stitch
using a 5mm hook, or size needed
to obtain correct tension

MEASUREMENTS

Toddler Hat measures approx 39cm
(15½in) in circumference
Child Hat measures approx 46cm
(18in) in circumference

ABBREVIATIONS

standing dc Place slip knot on hook,
insert hook in st/sp indicated, yrh
and pull up a loop, yrh and pull
through 2 loops on hook

standing tr Place slip knot on hook,
yrh, insert hook in st/sp indicated,
yrh and pull up a loop, (yrh and pull
through 2 loops) twice

For a full list, see page 78 of
Simply Crochet magazine



The hat is worked in the round in a tall tube shape, then seamed up at the top

A cotton blend helps this quirky hat keep its shape, while a dash of acrylic promises a soft touch for tiny heads.

NOTES

Brim is worked first in rows.
The Main Body of the Hat is worked in rounds across the row-end edge of the Brim.
The top of the Hat is seamed together, and pompoms are added to each corner.
Hat is worked in 2 colourways and two sizes.
The Toddler Hat is written first with the Child Hat in brackets.

DOUBLE BOBBLE HAT

BRIM

Using Larimar (Axinite), ch6.

Row 1 Ss in second ch, ss in each ch across, turn. [5 ss]

Row 2 Ch1 (does not count as st throughout), ss in each st across, turn.

Rep Row 2 until 71 (87) rows have been worked in total.

Next row Ss the bl of the final row to the base of Row 1 to join into loop.

Fasten off.

MAIN BODY

Join Axinite (Morganite) with a standing tr in any row-end.

Round 1 (RS) Skip next row end, (tr in next 3 row ends, skip next row end) 17 (21) times, tr in next 2 row ends, ss to first tr. [54 (66) tr]

Fasten off.

Join Larimar (Axinite) with a standing dc in sp after standing tr of last round.

Round 2 (RS) Ch2, skip 3 tr, (dc in sp before next tr, ch2, skip 3 tr) 17 (21) times, ss to first dc. [18 (22) dc, 18 (22) ch-2 sps]

Fasten off.

Join Morganite (Rhodochrosite) with a standing tr in any ch-2 sp.

Round 3 (RS) 2tr in same sp, (skip dc, 3tr in next ch-2 sp) rep around to end, ss to first tr. [54 (66) tr]

Fasten off.

Join Larimar (Axinite) with a standing dc in sp before standing tr of last round.

Round 4 As Round 2.

Fasten off.

Round 5 Repeat Round 3 using Rhodochrosite (Larimar).

Fasten off.

Join Larimar (Axinite) with a standing dc in sp before standing tr of last round.

Round 6 As Round 2.

Round 7 Repeat Round 3 using Axinite (Morganite).

Fasten off.

Join Larimar (Axinite) with a standing dc in sp before standing tr of last round.

Round 8 As Round 2.

Rounds 9-12 Repeat Rounds 3-6.

CHILD SIZE ONLY

Rounds 13-14 Repeat Rounds 7-8.

Round 15 Repeat Round 3.

Fasten off leaving a long tail.

TO FINISH

Flatten the Hat so that there are 9 (11) 3-tr groups on each side.

With WS facing and using a tapestry needle, weave the long tail through the back loops only of both sides of the Hat to join a top.

Using any colour, make 2 pompoms and attach securely to either corner of the Hat.

Hangin' out

Winter blues got you in a slump? Kick back, relax and just chill with this laidback beanie

Made with
4ply yarn



SLOUCHY HAT



YOU WILL NEED

- Scheepjes Metropolis (75% Merino wool, 25% nylon, 50g/200m)
1 ball of each:
San Juan (027)
Monterrey (023)

- A 4mm (US G/6) hook
- A pompom maker

For yarn stockists contact
Scheepjes
www.scheepjes.com/en

TENSION

24 rows of slip stitch to measure 10cm (4in) using a 4mm hook, or size needed to obtain correct tension

MEASUREMENTS

Hat measures approx 50cm (19¾in) in circumference around head

ABBREVIATIONS

For a full list, see page 78 of *Simply Crochet* magazine

Mix up some chains and trebles, work with a fine yarn and ease up on your tension. You now know the secret to the slouch!

NOTES

Rib is worked in vertical rows of ss to create lots of stretch. This is then seamed together, and the Crown is worked around one long edge. There is a Stitch Diagram below, which you can refer to when working the Crown. The colours alternate each round. Do not fasten off but run the yarn between rounds on the WS of your work. The Crown is worked with RS facing throughout.

SLOUCHY HAT

RIB

Using San Juan, ch16.

Row 1 (RS) Ss in bl of second ch from hook and each ch across, turn. [15 sts]

Row 2 (WS) Ch1 (does not count as st throughout), ss in bl of each st across, turn.

Rows 3-119 As Row 2.

Rib is seamed on the next row.

Row 120 (WS) Ch1, working in fl of Row 119 and unworked loop of starting to ch, ss in each st across.

Do not fasten off.

CROWN

Cont with San Juan.

Round 1 (RS) Ch4 (counts as tr, ch1), skip next row-end, (tr in next row-end, ch1, skip next row-end) 59 times, ss to third ch of beg ch-4. [60 tr and 60 ch-1 sps]

Change to Monterrey.

Round 2 (RS) Ch1 (does not count as st throughout), dc in same st, *ch5, (skip ch-1 sp, skip tr) twice, working in front of Round 1, ss in row-end below next ch-1 sp, ch5, (skip tr, skip ch-1 sp) twice, dc in next tr; rep from * 11 times more and omitting last dc on final rep, ss to first dc. [24 ch-5 sps, 12 dc, 12 ss]

Change to San Juan.

On next round work all tr sts behind ch-sps on round below and into sts 2 rounds below.

Round 3 Ch1, dc in first st, *(ch1, skip ch-1 sp, tr in next tr) 4 times, ch1, dc in next dc on round below; rep from * around, ss to first dc. [48 tr, 12 dc and 60 ch-1 sps]

Change to Monterrey.

Round 4 Ch1, dc in same st, *ch5, (skip ch-1 sp,



The stitch pattern is created with short chains worked in front of the darker colour stitches

skip tr) twice, working in front of previous round, ss in next ch-1 sp 2 rounds below, ch5, (skip tr, skip ch-1 sp) twice, dc in next dc; rep from * 11 times more omitting last dc on final rep, ss to first dc.

Change to San Juan.

Rounds 5-43 Repeat Rounds 3-4, ending on a Round 3 rep.

Change to Monterrey.

Round 44 Ch1, dc in same st, *ch4, (skip ch-1 sp, skip tr) twice, working in front of previous round, ss in next ch-1 sp 2 rounds below, ch4, (skip tr, skip ch-1 sp) twice, dc in next dc; rep from * 11 times more, omitting last dc on final rep, ss to first dc.

Change to San Juan.

Round 45 Ch1, dc in same st, *(skip ch-1 sp, tr in next tr) 4 times, dc in next dc of round below; rep from * around omitting last dc, ss to first dc. [48 tr and 12 dc]

Fasten off San Juan.

Change to Monterrey.

Round 46 Ch1, dc in same st, *ch3, skip 2tr, working in front of previous round, ss in next ch-1 sp 2 rounds below, ch3, skip 2tr, dc in next dc; rep from * 11 times more, omitting last dc on final rep, ss to first dc.

Round 47 Ch1, dc in same st, (skip ch-3 sp, tr in ss, skip ch-3 sp, dc in dc) 11 times, tr in final ss, ss to first dc. [24 sts]

Fasten off leaving a long tail.

Weave tail through sts of final round and pull tight to close.

TO FINISH

Using Monterrey, make a pompom and sew to the top of the Hat.

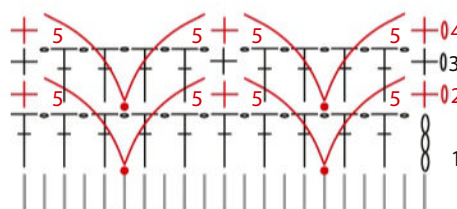

Key

- T Treble (tr)
- + Double crochet (dc)
- Slip stitch (ss)
- Chain (ch)
- ∩ Chain 5 (ch5)
- | Row-end on rib

HOW TO MAKE A POMPOM

HOW DO I USE A POMPOM MAKER?

It's easy when you know how...

You can make pompoms with almost any yarn, but different fibres will give you different results. Wool fibres produce a fluffy pompom, while cotton has a heavier feel – and the weight of the yarn will also affect the final result. In this example, we've used an aran-weight acrylic yarn to produce a light and fluffy pompom.

Step 1 Secure the end of the yarn in one of the prong's grooves, then start wrapping the yarn around the outside of the prongs. Keep wrapping the yarn around until the two prongs are fully covered. The more you wrap, the denser the pompom will be.

Step 2 Tie a length of yarn around the centre of the wrapped yarn.

Tighten it to secure the wrapped yarn at the centre and knot it a few times to hold the yarn ball in place.

Step 3 Slide the yarn off the prongs. Cut through the loops of yarn on either side of the knot. Once you've cut through all of the loops, the pompom will begin to take its shape.

Step 4 Trim the pompom so that the strands are roughly the same length and the pompom is an even sphere. The more you trim the denser the pompom will be. Take care not to cut through the central tie, as this will cause the pompom to collapse.

Tip Soaking a pompom in warm water (no soap) helps it to fluff up.



SCAN ME

Visit our website
for pompom
tutorials:
bit.ly/43Hn2T8



Walkthroughs

Step-by-step guides and stitch tutorials to help you make the hats in this collection

SIMPLE STEPS HOW TO WORK INTO THE BACK LOOP



1 The top of a stitch has 2 loops: one at the front and one at the back. To work a dc in the back loop, insert your hook under the loop at the back of the stitch.



2 Yrh and pull through the back loop of the stitch.



3 Yrh and pull through the 2 loops on your hook. This completes the double crochet worked into the back loop.



4 If you work a whole row in the back loop, you'll be left with a ridge at the base of this row. This is made up of the unused front loops from the row below.

SIMPLE STEPS HOW TO WORK A PUFF STITCH



1 Wrap yarn round hook (yrh), insert hook into stitch indicated, yrh and pull through a loop of yarn. Bring the loop up to the same height as a treble stitch.

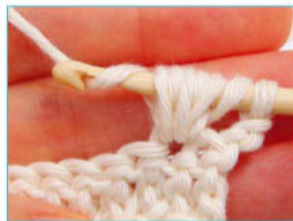

2 Repeat from * in Step 1 twice more (or as instructed in the pattern). You will now have 7 loops on the hook. Work yrh and carefully pull this through all the loops on the hook.

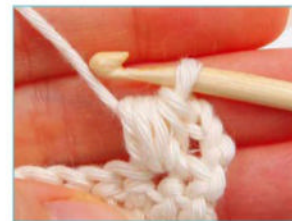

3 You will have formed a puff stitch with 3 repeats. Vary the number of repeats from * to create a puff stitch with 4 or 5 repeats – the more repeats you work, the larger the puff stitch will look.

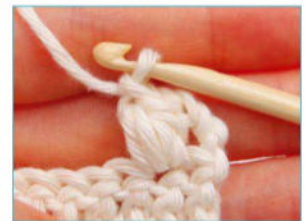

4 To secure and complete the puff stitch, chain 1 (yrh and pull through 1 loop). On the next row, the pattern may or may not ask you to work into this chain and/or the top loop of the puff st.



MEET THE DESIGNER: LUCY CROFT

Lucy loves bold colour combinations like those seen in her iconic Hook 'n' Learn blanket from 2018, which encouraged readers to try new stitches and techniques month by month. "There are so many intricate and varied ways to use crochet," Lucy says, "but so often we fall back on the usual double and treble crochet stitches. Sometimes it's nice to challenge ourselves a little and have a go at more complicated stitch patterns." Cue this gorgeous collection of hats, hot off her hook which showcases chunky cables, beautiful block stitch and a stunning two-colour stranded chain technique which is a lot easier than you'd think! If, like us, you're a fan of Lucy's work, make sure to check out her other impressive makes such as the William Morris project bag (issue 167), beachy cover-up skirt (issue 165) and cosy patchwork vest (issue 161). You can find Lucy's patterns on Ravelry and follow her on Instagram: @lucycroft





Simply
Crochet

Presented with issue 170 of *Simply Crochet*. Printed in the UK.